

CYB226: Introduction to Cryptography (2 Units)

Introduction

CYB 226: Introduction to Cryptography, is a two-credit unit course that exposes you to the art of securing information or data through coding and encryption. This course delves into the fundamentals of cryptography, a crucial aspect of cybersecurity that combines computer science, engineering, and mathematics to create complex codes. By the end of this course, you will gain a comprehensive understanding of cryptography, including its types (Symmetric and Asymmetric) and key concepts (Block Ciphers, Stream Ciphers, Data Encryption Standard, etc.), as well as its vital roles in computer and network security. Additionally, you will appreciate the significance of cryptography and its far-reaching applications across various aspects of human endeavors, enabling you to understand its significant roles in the advancement of computer technology.

Course Aims

The course aims to give you understanding of the concepts of cryptography. It provides the fundamental knowledge of the principles that support the application of cryptography in computer technology and other related fields and also assists you to fully grasp the meaning of various cryptographic protocols. These aims will be achieved by:

- i. Introducing you to a solid understanding of the basic principles and concepts of cryptography, including confidentiality, integrity, authenticity, and non-repudiation.
- ii. Equipping you with the theoretical knowledge and skills to design, implement, and analyze various encryption techniques, including symmetric and asymmetric encryption, block ciphers, and public-key cryptography.
- iii. Enabling you to understand and evaluate cryptographic protocols and algorithms, including digital signatures, message authentication codes, and hash functions.
- iv. Describing on how cryptographic principles and techniques are applied to real-world scenarios, ensuring secure communication and data protection in various applications and environments.

Course Objectives

In the light of the aforementioned aims, the course objectives are laid down as follows:

- i. To understand the basic concepts of cryptography, including confidentiality, integrity, authenticity, and non-repudiation.
- ii. To understand various encryption techniques, such as symmetric and asymmetric encryption, block ciphers, and public-key cryptography.
- iii. To understand digital signatures, message authentication codes, and hash functions.
- iv. To study the cryptographic protocols and algorithms.

Working through this course

To successfully complete this course, thoroughly read each study unit and additional resources listed in the Further Reading section. Each unit includes Self-Assessment Exercises (SAEs) and Tutor Marked Assignments (TMAs), which must be submitted at each course milestone for assessment. The course culminates in a final examination. The course outline details all necessary information, including course components and tasks allocations to help you complete the course efficiently.

Course materials

Major components of the course are:

- i. Course Guide
- ii. Study Units
- iii. References

Study Units

The course is made up of four modules; module 1 sets the stage for the course, providing a comprehensive overview of cryptography in computer science. We will delve into the basics of cryptography, its core principles, and its vital roles in computer and network security.

Additionally, we will explore the essential mathematical concepts of Number Theory and Modular Mathematics, which are crucial for a deep understanding of cryptography. By the end of this

module, you will have a solid grasp of the fundamentals of cryptography and its mathematical underpinnings, preparing you for the more advanced topics in cryptography.

Modules 2 and 3 build on the foundational knowledge from Module 1, delving deeper into the world of cryptography. Both modules explore the different types of cryptography and introduce the concept of secret keys, which are crucial for secure communication. You will learn about fundamental concepts such as Block Ciphers, Stream Ciphers, and Encryption, as well as Classical Cryptography and the various Modes of Operation for secret keys. Having explored the intricacies of cryptography, Module 4 will serve as a guide to understanding the practical applications of cryptography in the field of computer technology. By the end of this module, you will possess a thorough understanding of various cryptographic techniques and their real-world applications. The study units in the course are as follows:

Module 1: Overview of Cryptography

Unit 1: Foundations of Cryptography

Unit 2: Fundamental understanding of cryptography

Unit 3: Number Theory and Modular Arithmetic

Unit 4: Roles of cryptography in computer and network security

Module 2: Types of Cryptography

Unit 1: Symmetric Cryptography

Unit 2: Classical Cryptography

Unit 3: Modern Block Ciphers (Data Encryption Standards, AES, Mode of operations)

Unit 4: Stream Ciphers (Concept, Advantages, and Disadvantages)

Module 3: Clarifications of Complex Cryptographic Concepts

Introduction

Unit 1: Asymmetric Cryptography and Key Management

Unit 2: Asymmetric Cryptography (Diffie-Hellman key exchange, One-Way Functions, RSA, El Gamal cryptosystem)

Unit 3: Key Management (Importance, Standards, Public Key Infrastructure, Certificates, Certification Authority)

Unit 4: Digital Signature and Message Integrity (Methods, Hash functions, Digital Signature Systems)

Module 4: Practical Applications of Cryptography

Unit 1: Applications and Advanced Topics in Cryptography

Unit 2: Authentication and Identification (Protocols, Challenge-Response)

Assessment

The course assessment comprises three key components: Self-Assessment Exercises (SAEs), tutor-marked assignments (TMAs), and a comprehensive written examination. When tackling assignments, authentic and diligent effort is expected, applying the knowledge and skills gained throughout the course. Adhere to formal deadlines outlined schedule and submit your assignment file and TMAs to your tutor for assessment, which will account for 40% of the total course mark. The course concludes with a two-hour written examination, constituting of the total course mark.

Tutor Marked Assignments (TMAs)

Tutor-marked assignments (TMAs) are provided for each study unit in this course. To complete these assignments, rely on the information and materials from your reading and study units, but also consider supplementing with wider reading and research to deepen your understanding. Upon completing each assignment, submit it along with the TMA form to your tutor by the deadline stated in the presentation schedule and assignment file. If you face difficulties meeting the

deadline, contact your tutor in advance to discuss possible extensions. Note that extensions will only be granted in exceptional circumstances and not after the due date.

Module 1: Overview of Cryptography

Introduction

This introductory module lays the groundwork for the course, providing a comprehensive overview of cryptography. We will cover the basics of cryptography, its key concepts, and its vital importance in securing computer systems and networks. Additionally, we'll explore the fundamental mathematical concepts of Number Theory and Modular Mathematics, which are essential for understanding the inner workings of cryptography.

Unit 1: Foundations of Cryptography

Unit 2: Fundamental understanding of cryptography

Unit 3: Number Theory (Divisibility and Prime numbers, Congruences and Modular Arithmetic, GCD and Euclid's Algorithm, Euler's Theorem, Fermat's Theorem, , Chinese Remainder Theorem, and Discrete Logarithm)

Unit 4: Roles of cryptography in computer and network security

UNIT 1: Foundations of Cryptography

Contents

- 1.0 Introduction
- 2.0 Basic Cryptographic Building Blocks
- 3.0 Main Content
 - 3.1 Cryptographic Building Blocks
 - 3.2 Number Theory
- 4.0 Discussion
- 5.0 Self-Assessment Exercise(s)
- 6.0 Conclusion
- 7.0 Summary
- 8.0 Tutor Marked Assignment
- 9.0 Further Readings

1.0 Introduction

This unit offers an introduction to the core principles, techniques, and methods of cryptography, covering the essential tools and concepts needed to understand cryptographic applications. We start by exploring key cryptographic building blocks, including one-way functions, pseudorandomness, and zero-knowledge proofs, as well as fundamental Number Theory concepts like Euler's Theorem, Fermat's Theorem, Euclid's Algorithm, Chinese Remainder Theorem, and Discrete Logarithm. With a solid grasp of these foundations, we then delve into the development of critical cryptographic applications, including encryption techniques, digital signature schemes, and secure protocol design, providing a comprehensive understanding of cryptographic principles and practices.

2.0 Intended Learning Outcomes (ILOs)

By the end of this unit, you should be able to:

- Understand the fundamental principles of cryptography
- Recognize the importance of cryptographic building blocks

3.0 Main Content

3.1 Cryptographic Building Blocks

Cryptography relies on several fundamental building blocks to ensure secure communication. These cryptographic building blocks encompass a broader range of fundamental components from which cryptographic systems are constructed. They include cryptographic functions, protocols and techniques. Ciphers are also prominent components of cryptographic building blocks.

- **Ciphers**

Ciphers are algorithms used to encrypt and decrypt data. They are mathematical functions that transform plaintext (readable data) into ciphertext (unreadable data) and vice versa. Ciphers are fundamental building blocks of cryptography, providing confidentiality, integrity, and authenticity in various applications, such as secure communication protocols, digital signatures, and encryption scheme. They are a crucial component of modern cryptography, and their development and analysis have a rich history in mathematics and computer science.

- **Types of Ciphers**

There are two main types of Ciphers based on key usage, which are Symmetric key Ciphers and Asymmetric Key Ciphers

- Symmetric-key ciphers: Use the same key for both encryption and decryption. Examples include AES (Advanced Encryption Standard) and DES (Data Encryption Standard).
- Asymmetric-key ciphers: Use a pair of keys: a public key for encryption and a private key for decryption. Examples include RSA (Rivest-Shamir-Adleman) and elliptic curve cryptography.

Furthermore, Ciphers can be classified into different types based on their structure and operation:

- Block ciphers: Divide data into fixed-length blocks and encrypt each block independently. Examples include AES and DES.
- Stream ciphers: Encrypt data one bit or byte at a time. Examples include RC4 (Rivest Cipher 4) and FISH (Fast and Simple Hash).
- Hash functions: One-way ciphers that produce a fixed-size output from variable-size input data. Examples include SHA-256 (Secure Hash Algorithm 256) and MD5 (Message-Digest Algorithm 5).

Types of Cryptography

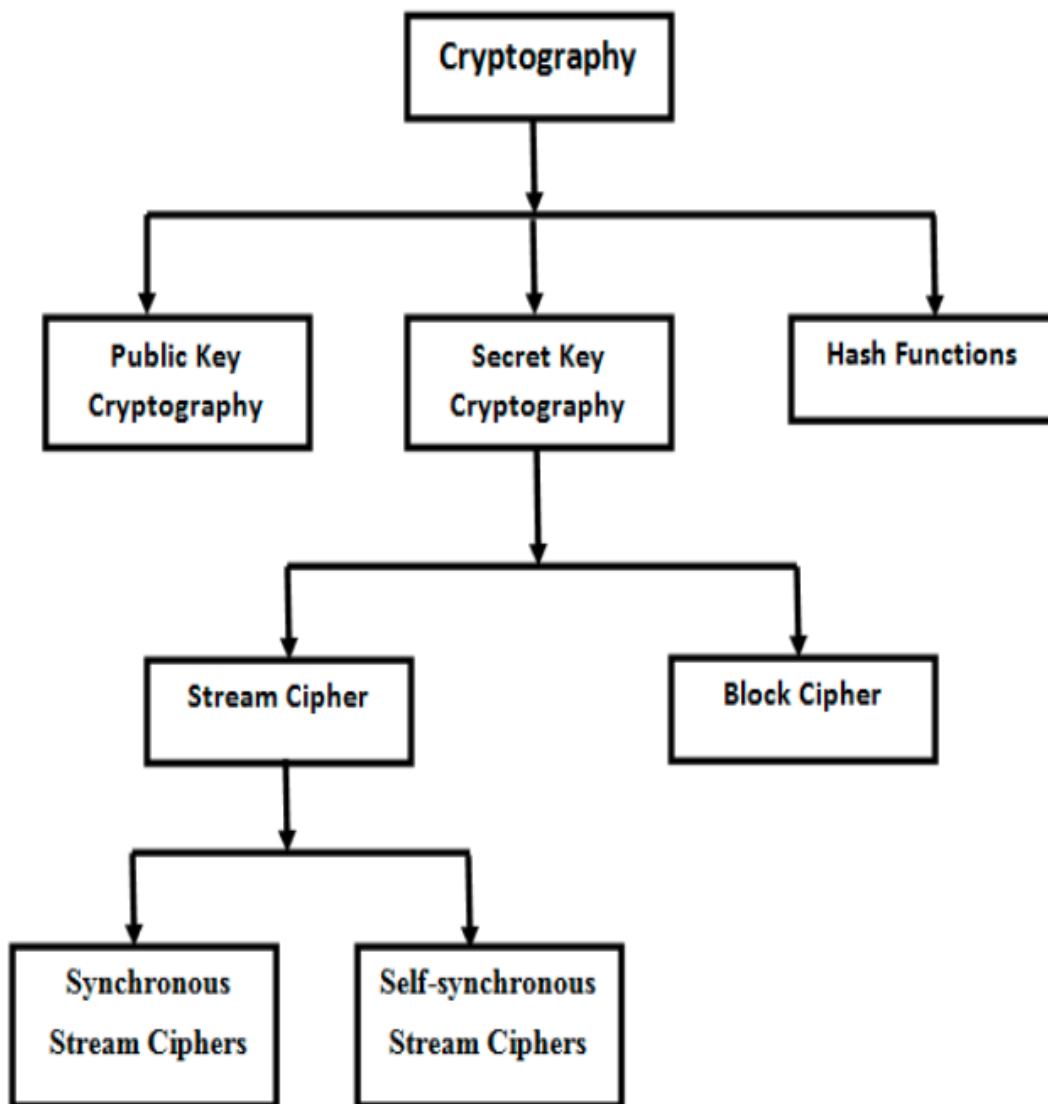

(From Singh, P., Kaur, S., & Singh, S. 2015)

3.2 Number Theory

Number Theory is a branch of mathematics that deals with the properties and behavior of integers and other whole numbers. In cryptography, Number Theory plays a crucial role in ensuring the security and integrity of cryptographic systems. Its basic application involves usage of prime numbers for instance. Prime numbers are used to generate public and private keys in asymmetric cryptography. Large prime numbers are used to create secure keys. It involves the application of important mathematical concepts such as Modular Mathematics, Euler's Theorem, Fermat's Theorem, Euclid's Algorithm, Chinese Remainder Theorem, and Discrete Logarithm. Number Theory provides the mathematical foundations for many cryptographic algorithms, including RSA (Rivest-Shamir-Adleman), Diffie-Hellman key exchange, ElGamal encryption, Elliptic Curve Cryptography (ECC) and Digital signatures (e.g., DSA, ECDSA).

4.0 Discussion

This unit provides a comprehensive introduction to cryptography, laying the groundwork for the course. It covers the basics of cryptography, its key concepts, and its vital importance in securing computer systems and networks. The unit delves into the fundamental mathematical concepts of Number Theory and Modular Mathematics, essential for understanding cryptography's inner workings.

You are introduced to cryptographic building blocks, including ciphers, one-way functions, pseudorandomness, and zero-knowledge proofs. Ciphers are explored in-depth, including symmetric-key and asymmetric-key ciphers, block ciphers, stream ciphers, and hash functions. Number Theory's role in cryptography is emphasized, with applications in generating public and private keys, digital signatures, and secure protocol design.

The course aims to you students with a solid understanding of cryptographic principles and practices. By the end of this unit, you should be able to comprehend cryptography's fundamental principles, recognize the importance of cryptographic building blocks, and apply mathematical concepts to secure communication and data protection.

- Key topics covered include:
 - Cryptography's basics and importance
 - Cryptographic building blocks (ciphers, one-way functions, pseudorandomness)
 - Number Theory's application in cryptography (prime numbers, modular mathematics)
 - Cipher classification (symmetric-key, asymmetric-key, block, stream, hash functions)
 - Cryptographic applications (encryption, digital signatures, secure protocols)

Through self-assessment exercises and tutor-marked assignments, you would demonstrate their understanding of cryptography's core concepts and tools. The unit concludes with recommendations for further reading, providing students with a comprehensive foundation for exploring cryptography's complexities.

This unit establishes a solid base to build your knowledge on cryptography, ensuring a deep understanding of its principles and practices. By mastering these fundamentals, you are well-prepared to tackle advanced cryptographic concepts and applications.

5.0 Self-Assessment Exercise(s)

1. What is a Cipher?
2. Can you explain different types of Ciphers based on the two criteria mentioned in the unit?
3. Can you explain Number Theory in Cryptography?

Here are the answers to the above self-assessment exercises:

Exercise 1: What is a Cipher?

A cipher is an algorithm used to encrypt and decrypt data, converting plaintext (readable data) into ciphertext (unreadable data) and vice versa, to secure communication and protect information.

Exercise 2: Can you explain different types of Ciphers based on the two criteria mentioned in the unit?

The two criteria are key usage and structure/operation.

Based on key usage, ciphers are classified into:

- Symmetric-key ciphers: Use the same key for encryption and decryption (e.g., AES, DES).
- Asymmetric-key ciphers: Use a pair of keys (public key for encryption, private key for decryption) (e.g., RSA, elliptic curve cryptography).

Based on structure/operation, ciphers are classified into:

- Block ciphers: Divide data into fixed-length blocks and encrypt each block independently (e.g., AES, DES).
- Stream ciphers: Encrypt data one bit or byte at a time (e.g., RC4, FISH).
- Hash functions: One-way ciphers producing fixed-size output from variable-size input data (e.g., SHA-256, MD5).

Exercise 3: Can you explain Number Theory in Cryptography?

Number Theory plays a crucial role in cryptography, particularly in:

- Prime numbers: Used to generate public and private keys in asymmetric cryptography.
- Modular mathematics: Essential for cryptographic algorithms (e.g., RSA, Diffie-Hellman key exchange). Euler's Theorem, Fermat's Theorem, Euclid's Algorithm, Chinese Remainder Theorem, and Discrete Logarithm: Mathematical concepts applied in cryptographic algorithms.

Number Theory provides the mathematical foundations for many cryptographic algorithms, ensuring secure data transmission and protection.

6.0 Conclusion

In this unit, we have explored the fundamental principles, techniques, and methods of cryptography, providing a comprehensive understanding of the core concepts and tools necessary for secure communication and data protection. We have delved into the key cryptographic building blocks, including one-way functions, pseudorandomness, and zero-knowledge proofs, as well as essential Number Theory concepts.

7.0 Summary

This unit introduces the principles and techniques of cryptography, covering key concepts, building blocks (ciphers), and applications (encryption, digital signatures, secure protocols). It provides a comprehensive understanding of cryptography for secure communication and data protection.

8.0 Tutor-Marked Assignments

1. What are the two main types of ciphers based on key applications, and provide an example of each?
2. What is the role of Number Theory in cryptography, and name one important mathematical concept used in cryptographic algorithms?
3. What are the three types of ciphers classified based on their structure and operation, and provide an example of each?

9.0 Further Reading

Bootyman, D. (2002). Introduction to cryptography, by Johannes A. Buchmann. Pp. 281.£ 24. 2001. ISBN 0 387 95034 6 (Springer Verlag). *The Mathematical Gazette*, 86(507), 560-562. https://www.researchgate.net/publication/220688034_Introduction_to_Cryptography

Goldreich, O. (2019). On the foundations of cryptography. In *Providing sound foundations for cryptography: on the work of Shafi Goldwasser and Silvio Micali* (pp. 411-496). <https://dl.acm.org/doi/10.1145/3335741.3335759>

Pucella, R. (2003). Foundations of Cryptography: Basic Tools.

Shannon, C. E. (1949). Communication theory of secrecy systems. *The Bell system technical journal*, 28(4), 656-715. <https://ieeexplore.ieee.org/document/6769090>

UNIT 2: Fundamental Understanding of Cryptography

Contents

1.0 Introduction

2.0 Intended Learning Outcomes

3.0 Main Content

 3.1 History and Definition of Cryptography

 3.2 Fundamental Concepts and Principles of Cryptography

4.0 Discussion

5.0 Self-Assessment Exercise(s)

6.0 Conclusion

7.0 Summary

8.0 Tutor Marked Assignment

9.0 Further Readings

1.0 Introduction

From ancient civilizations to modern times, cryptography has played a crucial role in shaping the course of human history, influencing everything from military communications to financial transactions. As previously discussed, cryptography is about transforming information into a code that can only be deciphered by those with the proper authorization. This is achieved through the use of complex algorithms, keys, and ciphers, which work together to ensure the confidentiality, integrity, and authenticity of data. In this unit, we will delve into the fascinating world of cryptography, exploring its rich history and fundamental concepts.

2.0 Intended Learning Outcome

Understand the basic definitions and concepts of cryptography, including:

- Confidentiality
- Integrity
- Authenticity

- Encryption

3.0 Main Content

3.1 History and Definition of Cryptography

Cryptography was derived from the Greek words "kryptos" (hidden) and "graphein" (writing), refers to the practice and study of techniques for secure communication in the presence of third-party adversaries. The goal of cryptography is to ensure the confidentiality, integrity, and authenticity of messages, by transforming plaintext (readable data) into ciphertext (unreadable data) using algorithms and keys

3.2 Fundamental Concepts and Principles of Cryptography

Cryptography is the practice of protecting the confidentiality, integrity, and authenticity of information by using mathematical algorithms and secret keys. Here are the fundamental concepts and principles of cryptography:

- Confidentiality: Protecting information from unauthorized access.
- Integrity: Ensuring that information is not modified or tampered with.
- Authenticity: Verifying the identity of the sender and ensuring that the information comes from a trusted source.
- Encryption: Converting plaintext (readable data) into ciphertext (unreadable data) using an algorithm and a secret key.
- Decryption: Converting ciphertext back into plaintext using the corresponding decryption algorithm and secret key.

The aforementioned concepts are discussed as follows:

- **Confidentiality**

In the context of cryptography, confidentiality refers to the protection of information from unauthorized access, use, or disclosure. It ensures that sensitive data remain secret and is only accessible to the intended parties. Confidentiality measures, such as encryption, are designed to prevent eavesdropping, interception, and unauthorized reading of sensitive information. In other words, confidentiality ensures that only authorized individuals or systems can access and read the

information, while unauthorized parties are prevented from doing so. This is a critical aspect of cryptography, as it helps maintain the secrecy and privacy of sensitive information.

- **Integrity**

Integrity refers to the assurance that information is not modified, tampered with, or altered during transmission or storage. It ensures that the data received is identical to the data sent, and that no unauthorized modifications or changes have been made. Integrity measures, such as digital signatures and message authentication codes (MACs), are designed to detect any changes or tampering with the data, ensuring that the information remains accurate, reliable, and trustworthy. In essence, integrity guarantees that the data is genuine, authentic, and has not been tampered with, and this is essential for maintaining the reliability and trustworthiness of the information.

- **Authenticity**

In the context of cryptography, authenticity refers to the verification of the identity of the sender or source of the information, and ensuring that the information comes from a trusted and genuine source. It confirms that the message or data has not been tampered with or impersonated by an unauthorized party.

Authenticity measures, such as digital signatures and certificates, are used to verify the identity of the sender and ensure that the information is genuine and trustworthy. This ensures that the receiver can trust the source of the information and be confident that it has not been tampered with or falsified.

- **Encryption**

Encryption is the process of converting plaintext (readable data) into ciphertext (unreadable data) using an algorithm and a secret key. It ensures that even if an unauthorized party gains access to the data, they will not be able to read or exploit it, as it will appear as a scrambled and meaningless sequence of characters.

Encryption is a fundamental concept in cryptography, and it provides confidentiality, privacy, and security for data. It is widely used to protect sensitive information, such as financial data, personal

identifiable information, and confidential communications. Various types of encryption include Symmetric Encryption, Asymmetric Encryption, Hash-based Encryption e.t.c

- **Decryption**

Decryption is the process of converting ciphertext (unreadable data) back into plaintext (readable data) using an algorithm and a secret key. It is the reverse process of encryption, and it allows authorized parties to access and read the encrypted data. Decryption requires the same algorithm and key used for encryption, and it ensures that the decrypted data is identical to the original plaintext. This process enables authorized parties to access and utilize the encrypted data, while maintaining the confidentiality and security of the information.

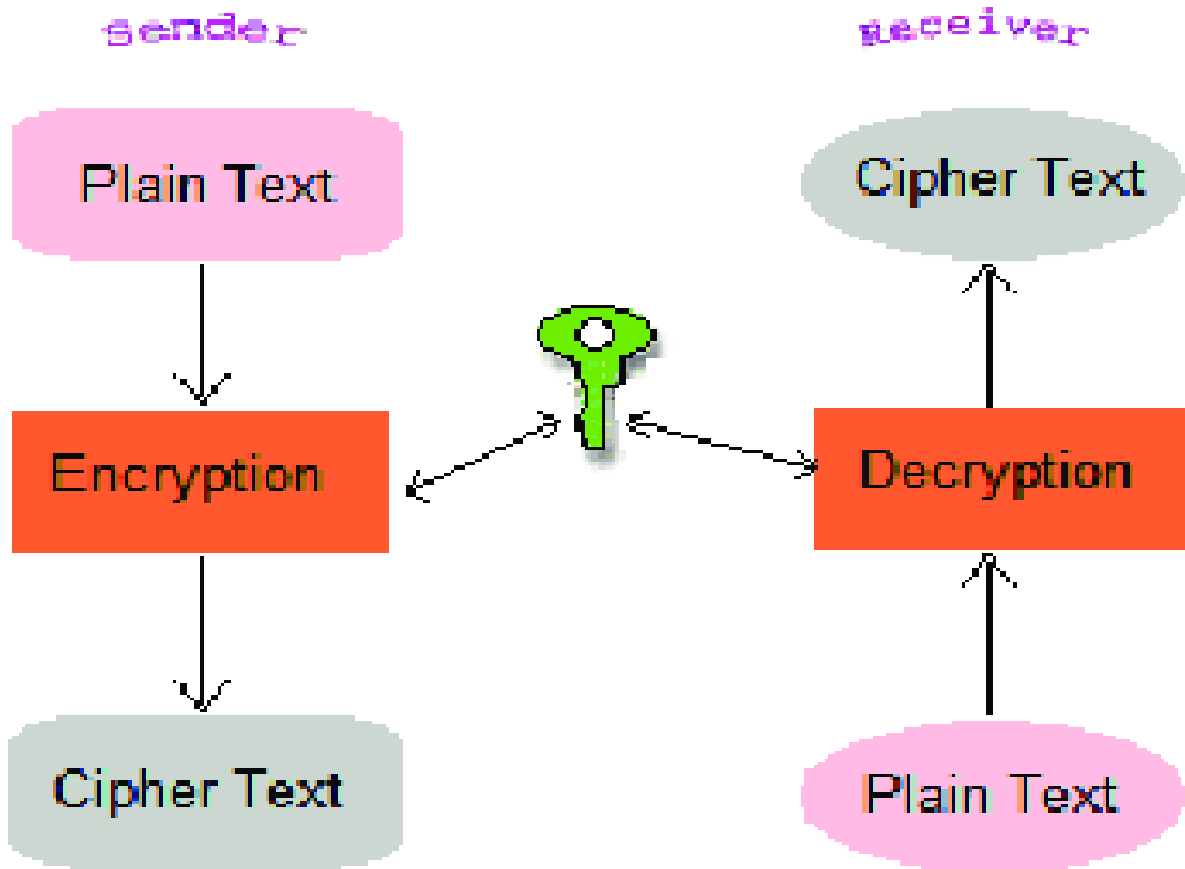

(From Hussain, M., 2011)

4.0 Discussion

This unit delves into the fundamental understanding of cryptography, exploring its rich history, definitions, and core concepts. Cryptography, derived from Greek words meaning "hidden writing," involves transforming information into a code accessible only to authorized parties. This is achieved through complex algorithms, keys, and ciphers ensuring confidentiality, integrity, and authenticity.

The unit discusses cryptography's primary objectives: confidentiality, integrity, and authenticity. Confidentiality protects information from unauthorized access, ensuring sensitive data remains secret. Integrity guarantees information is not modified or tampered with during transmission or storage. Authenticity verifies the sender's identity and ensures information comes from a trusted source.

Encryption, a fundamental concept, converts plaintext into ciphertext using algorithms and secret keys. This protects sensitive information, making it unreadable to unauthorized parties. Various encryption types include symmetric, asymmetric, and hash-based encryption. Decryption reverses this process, converting ciphertext back into plaintext for authorized access. Cryptography's significance extends beyond secure communication to influencing military strategies, financial transactions, and data protection. Understanding these fundamental concepts and principles is crucial for appreciating cryptography's role in modern security.

By exploring cryptography's history, definitions, and core concepts, this unit provides a comprehensive foundation for further exploration. Key concepts, such as confidentiality, integrity, authenticity, encryption, and decryption, form the backbone of cryptography, enabling secure data transmission and protection.

Upon completion, you are equipped with the essential principles of cryptography, including:

- Confidentiality measures to protect sensitive information
- Integrity mechanisms to prevent data tampering
- Authenticity verification to ensure trustworthy sources
- Encryption and decryption processes for secure data transmission

This unit lays the groundwork for advanced cryptographic concepts and applications, equipping learners with a deep understanding of cryptography's critical role in modern security and data protection.

5.0 Self-Assessment Exercise(s)

1. Explain the concept of confidentiality in cryptography and its importance in maintaining data secrecy.
2. Describe the difference between encryption and decryption, and explain the roles of algorithms and secret keys in these processes.
3. Explain the concept of authenticity in cryptography.

Answers

Exercise 1: Explain the concept of confidentiality in cryptography and its importance in maintaining data secrecy.

Confidentiality in cryptography refers to the protection of information from unauthorized access, use, or disclosure. It ensures that sensitive data remains secret and is only accessible to intended parties. Confidentiality is crucial in maintaining data secrecy as it:

- Prevents eavesdropping and interception
- Protects sensitive information from unauthorized reading
- Ensures data privacy and security
- Maintains trust between communicating parties

Importance:

- Prevents financial loss through data theft
- Protects personal identifiable information
- Maintains national security
- Supports compliance with data protection regulations

Exercise 2: Describe the difference between encryption and decryption, and explain the roles of algorithms and secret keys in these processes.

Encryption:

- Converts plaintext (readable data) into ciphertext (unreadable data)
- Uses algorithms and secret keys
- Protects data from unauthorized access

- Ensures confidentiality and security

Decryption:

- Converts ciphertext back into plaintext
- Uses corresponding decryption algorithm and secret key
- Enables authorized access to encrypted data
- Maintains data integrity

Role of algorithms:

- Transforms plaintext into ciphertext (encryption)
- Transforms ciphertext back into plaintext (decryption)
- Provides secure data transmission

Role of secret keys:

- Controls access to encrypted data
- Ensures only authorized parties can decrypt data
- Maintains confidentiality and security

Exercise 3 : Explain the concept of authenticity in cryptography.

Authenticity in cryptography verifies the identity of the sender or source of information, ensuring:

- Information comes from a trusted source
- Data has not been tampered with or impersonated
- Receiver can trust the source and content

Authenticity measures:

- Digital signatures
- Certificates
- Message authentication codes (MACs)

Importance:

- Prevents impersonation and data tampering
- Ensures trustworthiness and reliability
- Supports compliance with security regulations
- Maintains data integrity and confidentiality

6.0 Conclusion

This unit has made us to understand that cryptography is a critical component of modern data security, ensuring the confidentiality, integrity, and authenticity of information. Through the use of encryption, decryption, and various algorithms and keys, cryptography protects sensitive data from unauthorized access and tampering. Understanding the fundamental concepts and principles of cryptography, including confidentiality, integrity, authenticity, encryption, and decryption, is essential for maintaining the secrecy, privacy, and security of information in today's digital age. By applying cryptographic techniques, individuals and organizations can safeguard their sensitive information and trust that their data remains secure and reliable..

7.0 Summary

Cryptography is a crucial method for secure communication, ensuring confidentiality, integrity, and authenticity of information. It protects data through encryption and decryption, using algorithms and keys. Understanding cryptography's fundamental concepts is essential for maintaining data secrecy, privacy, and security in today's digital world.

8.0 Tutor Marked Assignment

1. Explain the concept of confidentiality in cryptography, highlighting its importance and measures used to achieve it.
2. Compare and contrast the concepts of integrity and authenticity in cryptography. Describe the measures used to ensure integrity and authenticity, including digital signatures and message authentication codes (MACs).
3. Describe the process of encryption and decryption, highlighting the role of algorithms and secret keys. Explain the differences between symmetric, asymmetric, and hash-based encryption

9.0 Further Reading

Van Tilborg, H. C. (1999). *Fundamentals of cryptology: a professional reference and interactive tutorial*(Vol. 528).Springer Science & Business Media. <https://www.amazon.com/Fundamentals-Cryptology-Professional-Interactive-International/dp/0792386752>

Borda, M., & Borda, M. (2011). Cryptography Basics. *Fundamentals in Information Theory and Coding*.[researchgate.net/publication/267132447Fundamentals_in_Information_Theory_and_Coding](https://www.researchgate.net/publication/267132447Fundamentals_in_Information_Theory_and_Coding)

Singh, P., Kaur, S., & Singh, S. (2015). Cryptography: an art of data hiding. *International Journal of Computer and Communication System Engineering (IJCCSE)*, 2(1), 117-120.
https://www.researchgate.net/publication/277076733_Cryptography_An_Art_of_Data_Hiding

UNIT 3: NUMBER THEORY

Contents

1.0 Introduction

2.0 Intended Learning Outcomes

3.0 Main Content

3.1 Divisibility and Prime Numbers

3.2 Congruences and Modular Arithmetic

3.3 Greatest Common Divisors (GCDs) and Euclid's Algorithm

3.4 Number Theorems and their applications in Cryptography

4.0 Discussion

5.0 Self-Assessment Exercise(s)

6.0 Conclusion

7.0 Summary

8.0 Tutor Marked Assignment

9.0 Further Readings

1.0 Introduction

Number theory is a branch of mathematics that deals with the properties and behavior of integers and other whole numbers. It explores the relationships and properties of integers, including divisibility, prime numbers, congruences, and modular arithmetic. With roots in ancient civilizations, number theory has been a fundamental area of mathematics for thousands of years. The study of number theory has a rich history, with significant contributions from renowned mathematicians such as Euclid, Diophantus, Fermat, Euler, and Gauss. Their work has laid the foundation for modern number theory, which continues to evolve with new discoveries and applications emerging regularly. It is a fundamental area of mathematics that has numerous applications in cryptography, coding theory, and other fields.

The significance of number theory stems from its capacity to reveal the intricate patterns and connections within integers in cryptography. By uncovering these underlying structures, number theory's principles and theories have a profound impact, influencing our comprehension of mathematics and its applications in cryptography.

2.0 Intended Learning Outcomes

1. Identify the key concepts and principles of Number Theory, including divisibility, prime numbers, congruences, and modular arithmetic.
2. Understand how Number Theory reveals intricate patterns and connections within integers.
3. Appreciate the importance of Number Theory in cryptography.

3.0 Main Content

3.1 Divisibility and Prime Numbers in Cryptography

Divisibility in Cryptography

Divisibility is a fundamental concept in number theory, and it plays a crucial role in cryptography. In cryptography, divisibility is used to develop secure algorithms for encrypting and decrypting data. Two types of divisibility have been identified in cryptography which include:

- **Greatest Common Divisor (GCD):** The GCD of two numbers is the largest number that divides both numbers without leaving a remainder. In cryptography, the GCD is used to find the greatest common divisor of two large numbers, which is essential in algorithms like RSA.
- **Least Common Multiple (LCM):** The LCM of two numbers is the smallest number that is a multiple of both numbers. In cryptography, the LCM is used to find the least common multiple of two large numbers, which is essential in algorithms like Diffie-Hellman key exchange.

Prime Numbers in Cryptography

Prime numbers are numbers that are divisible only by themselves and 1. In cryptography, prime numbers play a vital role in developing secure algorithms. There are various concepts of prime numbers concepts have been deployed in the development of cryptographic algorithm. They include:

- **Large Prime Numbers:** Large prime numbers are used in cryptographic algorithms like RSA and Diffie-Hellman key exchange. These prime numbers are used to create public and private keys.
- **Prime Number Generation:** Prime number generation is an essential step in cryptographic algorithms. Prime numbers are generated randomly and tested for primality using algorithms like the Miller-Rabin primality test.
- **Prime Number Factorization:** Prime number factorization is the process of finding the prime factors of a large number. In cryptography, prime number factorization is used to break certain encryption algorithms.

Cryptographic Algorithms Using Divisibility and Prime Numbers

- **Diffie-Hellman Key Exchange:** The Diffie-Hellman key exchange algorithm uses divisibility and prime numbers to develop a secure key exchange protocol. It uses large prime numbers to generate public and private keys.
- **Elliptic Curve Cryptography:** Elliptic curve cryptography uses divisibility and prime numbers to develop a secure encryption algorithm. It uses large prime numbers to generate public and private keys.
- **RSA Algorithm:** The RSA algorithm uses divisibility and prime numbers to develop a secure encryption algorithm. It uses large prime numbers to generate public and private keys. To understand how the RSA algorithm works, we need to delve into some fundamental concepts of number theory, which is the study of whole numbers like 1, 2, 3, and so on. Specifically, let's focus on prime numbers, which are whole numbers that can only be divided evenly by 1 and themselves. For instance, 2, 3, and 5 are prime numbers, whereas 4 and 15 are not, since they have additional divisors (2 for 4 and 3 for 15). To

visualize this, imagine a table of the first 100 whole numbers, where the prime numbers are highlighted in white squares.

1	2	3	4	5	6	7	8	9	10
11	12	13	14	15	16	17	18	19	20
21	22	23	24	25	26	27	28	29	30
31	32	33	34	35	36	37	38	39	40
41	42	43	44	45	46	47	48	49	50
51	52	53	54	55	56	57	58	59	60
61	62	63	64	65	66	67	68	69	70
71	72	73	74	75	76	77	78	79	80
81	82	83	84	85	86	87	88	89	90
91	92	93	94	95	96	97	98	99	100

(image from <http://technomaths.edublogs.org/category/number/>)

3.2 Congruences and Modular Arithmetic

- **Congruences**

In number theory, a congruence is a statement about the relationship between two integers modulo a third integer. In other words, it's a way of saying that two numbers have the same remainder when divided by a third number.

Definition: Two integers a and b are said to be congruent modulo n , denoted as $a \equiv b \pmod{n}$, if they have the same remainder when divided by n .

Example: $17 \equiv 5 \pmod{4}$, because both 17 and 5 have a remainder of 1 when divided by 4.

- **Modular Arithmetic**

Modular arithmetic is a system of arithmetic operations performed on a set of integers modulo a fixed integer, called the modulus.

Definition: Modular arithmetic is a way of doing arithmetic operations (like addition, subtraction, multiplication, and division) on a set of integers, where the result is reduced to its remainder modulo a fixed integer n .

Example: In modular arithmetic modulo 7, the result of 3×4 is 5, because $(3 \times 4) \pmod{7} = 5$.

- **Congruences in Cryptography**

Congruences play a crucial role in cryptography, as they enable the development of secure encryption algorithms.

- **RSA Algorithm:** The RSA algorithm uses congruences to ensure the security of data transmission. It relies on the difficulty of factoring large numbers, which is related to congruences.
- **Diffie-Hellman Key Exchange:** The Diffie-Hellman key exchange algorithm uses congruences to enable secure key exchange over an insecure channel.

- **Modular Arithmetic in Cryptography**

Modular arithmetic is used extensively in cryptographic algorithms, including:

- **Modular Exponentiation:** Modular exponentiation is used in algorithms like RSA and Diffie-Hellman key exchange. It involves computing powers of numbers modulo a large number.
- **Modular Multiplicative Inverse:** The modular multiplicative inverse is used in algorithms like RSA. It involves finding the inverse of a number modulo a large number.
- **Modular Reduction:** Modular reduction is used to reduce large numbers to their remainder modulo a smaller number, ensuring efficient computation.

3.3 Greatest Common Divisors (GCDs) and Euclid's Algorithm

GCD and Euclid's Algorithm are fundamental concepts in cryptography and are used in various cryptographic algorithms and protocols to provide secure communication and data protection.

- **Greatest Common Divisors (GCDs)**

As mentioned earlier, GCD of two numbers is the largest number that divides both numbers without leaving a remainder. GCD of two integers a and b is the largest integer that divides both a and b without leaving a remainder. The GCD of two integers a and b is denoted as $\text{gcd}(a, b)$. For example the $\text{gcd}(12, 15) = 3$, since 3 is the largest integer that divides both 12 and 15 without leaving a remainder.

GCD is a fundamental concept in cryptography and is used in many cryptographic algorithms and protocols to provide secure communication and data protection.

- **Euclid's Algorithm**

This is a method for computing the GCD of two integers. It is based on the principle that the GCD of two numbers does not change if the larger number is replaced by its difference with the smaller number.

Steps:

1. If $b = 0$, return a (since $\text{gcd}(a, 0) = a$).

2. Otherwise, replace a with b and b with $a \bmod b$ (the remainder of a divided by b).
3. Repeat steps 1 and 2 until $b = 0$.
4. The GCD is the final value of a .

Example: Compute $\text{gcd}(12, 15)$ using Euclid's Algorithm:

1. $a = 12, b = 15$
2. $a = 15, b = 12 \bmod 15 = 3$
3. $a = 3, b = 0$ (since $3 \bmod 3 = 0$)
4. $\text{gcd}(12, 15) = 3$.

- **Applications of GCD and Euclid's Algorithm in cryptography**

- **Key Exchange:** GCD and Euclid's Algorithm are used in key exchange protocols, such as Diffie-Hellman and Elliptic Curve Diffie-Hellman, to establish a shared secret key between two parties.
- **Public-Key Cryptography:** GCD and Euclid's Algorithm are used in public-key cryptography, such as RSA, to find the private key from the public key.
- **Digital Signatures:** GCD and Euclid's Algorithm are used in digital signature schemes, such as RSA, to sign messages and verify the authenticity of the sender.
- **Cryptographic Protocols:** GCD and Euclid's Algorithm are used in various cryptographic protocols, such as SSL/TLS, IPsec, and PGP, to provide secure communication and data protection.
- **Modular Arithmetic:** GCD and Euclid's Algorithm are used in modular arithmetic to perform operations, such as modular exponentiation and modular multiplication, which are essential for many cryptographic algorithms.
- **Factorization:** GCD and Euclid's Algorithm are used to factor large numbers, which is an important problem in cryptography, as many cryptographic algorithms rely on the difficulty of factoring large numbers.
- **Primality Testing:** GCD and Euclid's Algorithm are used in primality testing algorithms, such as the Miller-Rabin primality test, to determine whether a number is prime or composite.
- **Key Generation:** GCD and Euclid's Algorithm are used in key generation algorithms, such as the RSA key generation algorithm, to generate keys for cryptographic algorithms.

3.4 Number Theorems and their applications in Cryptography

There are fundamental theorems in number theory that are applicable in cryptography such that their applications have contributed to the developments of cryptographic algorithms. These include:

Euler's Theorem: This is a fundamental theorem in number theory, named after Leonhard Euler. It states that for any positive integer n and any integer a that is coprime to n (i.e., $\gcd(a, n) = 1$), the following congruence holds:

$$a^{\varphi(n)} \equiv 1 \pmod{n},$$

where $\varphi(n)$ is Euler's totient function, which counts the number of positive integers less than or equal to n that are coprime to n . Euler's Theorem is a powerful tool in number theory and cryptography, and its applications continue to grow as new cryptographic protocols and algorithms are developed.

Euler's Theorem has many applications in cryptography, including:

- **Public-key cryptography:** Euler's Theorem is used in RSA and other public-key cryptosystems to ensure that the encryption and decryption processes work correctly.
- **Digital signatures:** Euler's Theorem is used in digital signature schemes, such as RSA, to verify the authenticity of messages.
- **Cryptographic protocols:** Euler's Theorem is used in various cryptographic protocols, such as SSL/TLS, to provide secure communication over the internet.

Fermat's Theorem: It is also known as Fermat's Little Theorem, is a fundamental theorem in number theory. It states that for any prime number p and any integer a , the following congruence holds:

$$a^p \equiv a \pmod{p}$$

In other words, if you take any integer a and raise it to the power of a prime number p , the result is congruent to a modulo p . It provides a way to secure communication, authenticate messages, and protect data from unauthorized access, therefore its importance in cryptography. Fermat's Theorem has several applications in cryptography, including:

- **RSA Algorithm:** Fermat's Theorem is used to find the private key in the RSA algorithm, which is a widely used public-key encryption algorithm.
- **Diffie-Hellman Key Exchange:** Fermat's Theorem is used to secure the Diffie-Hellman key exchange protocol, which is used to establish a shared secret key between two parties over an insecure channel.
- **Digital Signatures:** Fermat's Theorem is used in digital signature schemes, such as the RSA algorithm, to sign messages and verify the authenticity of the sender.
- **Modular Exponentiation:** Fermat's Theorem is used to perform efficient modular exponentiation, which is a critical operation in many cryptographic algorithms.
- **Primality Testing:** Fermat's Theorem is used in primality testing algorithms, such as the Miller-Rabin primality test, to determine whether a number is prime or composite.
- **Cryptographic Protocols:** Fermat's Theorem is used in various cryptographic protocols, such as SSL/TLS, IPsec, and PGP, to provide secure communication and data protection.
- **Key Generation:** Fermat's Theorem is used in key generation algorithms, such as the RSA key generation algorithm, to generate keys for cryptographic algorithms.
- **Secure Communication:** Fermat's Theorem is used to secure communication over insecure channels, such as the internet, by providing a way to encrypt and decrypt messages.

Chinese Remainder Theorem: It is a powerful tool for solving systems of congruences and has many practical applications in mathematics and computer science. It is a fundamental theorem in number theory, which states that:

"If n_1, n_2, \dots, n_k are pairwise coprime positive integers, and a_1, a_2, \dots, a_k are integers, then the system of congruences: $x \equiv a_1 \pmod{n_1}, x \equiv a_2 \pmod{n_2} \dots x \equiv a_k \pmod{n_k}$ has a unique solution modulo $n_1 \cdot n_2 \cdot \dots \cdot n_k$."

The Chinese Remainder Theorem (CRT) has several applications in cryptography, including:

- **RSA Algorithm:** The CRT is used in the RSA algorithm to improve the efficiency of decryption.
- **Diffie-Hellman Key Exchange:** The CRT is used in the Diffie-Hellman key exchange protocol to secure the exchange of keys.
- **Public-Key Cryptography:** The CRT is used in public-key cryptography to construct secure cryptographic protocols.
- **Digital Signatures:** The CRT is used in digital signature schemes, such as the RSA algorithm, to sign messages and verify the authenticity of the sender.
- **Secure Communication:** The CRT is used to secure communication over insecure channels, such as the internet.
- **Key Generation:** The CRT is used in key generation algorithms, such as the RSA key generation algorithm, to generate keys for cryptographic algorithms.
- **Cryptographic Protocols:** The CRT is used in various cryptographic protocols, such as SSL/TLS, IPsec, and PGP, to provide secure communication and data protection.
- **Modular Exponentiation:** The CRT is used to perform efficient modular exponentiation, which is a critical operation in many cryptographic algorithms.
- **Secure Multi-Party Computation:** The CRT is used in secure multi-party computation protocols to enable secure computation over private data.
- **Homomorphic Encryption:** The CRT is used in homomorphic encryption schemes to enable secure computation over encrypted data.

Discrete Logarithm: It is a fundamental problem in number theory and cryptography, which is popularly referred to as Discrete Logarithm Problem (DLP). It is mathematically defined as follows:

Given a prime number p , a generator g of a multiplicative group modulo p , and an element h in the group, find the integer x such that: $h \equiv g^x \pmod{p}$.

The discrete logarithm problem is considered "hard" because there is no known efficient algorithm to solve it for large primes p . This hardness is the basis for many cryptographic algorithms e.g. Diffie-Hellman key exchange, ElGamal encryption, Digital signatures (e.g., ECDSA), Cryptographic protocols (e.g., SSL/TLS, IPsec). The difficulty of the discrete logarithm problem

is based on the size of the prime number p and the generator g . For large primes, the problem is considered intractable, making it a fundamental building block for many cryptographic algorithms and protocols.

The discrete logarithm problem has several applications in cryptography, including:

- Key exchange and establishment
- Digital signatures and authentication
- Public-key encryption and decryption
- Secure communication and data protection

4.0 Discussion

This course unit delves into the fundamental concepts of Number Theory and its pivotal role in cryptography. Number Theory, a branch of mathematics, explores the properties and behaviors of integers, laying the groundwork for secure data transmission and protection. The unit examines the intricate relationships between integers, including divisibility, prime numbers, congruences, and modular arithmetic, which are essential components of cryptographic algorithms.

The study of Number Theory reveals intricate patterns and connections within integers, enabling the development of secure encryption algorithms. Cryptographic algorithms, such as RSA and Diffie-Hellman key exchange, rely heavily on Number Theory concepts, including prime numbers, congruences, and modular arithmetic. These algorithms ensure confidentiality, integrity, and authenticity of data, making them indispensable in modern secure communication.

Euclid's Algorithm, a fundamental concept in Number Theory, is used to compute the Greatest Common Divisor (GCD) of two integers. This algorithm plays a critical role in key exchange protocols, public-key cryptography, digital signatures, and cryptographic protocols. Additionally, Number Theory theorems, such as Euler's Theorem, Fermat's Theorem, and the Chinese Remainder Theorem, contribute significantly to the development of cryptographic algorithms. The Discrete Logarithm Problem (DLP), a fundamental problem in Number Theory, is a critical component of many cryptographic algorithms. The difficulty of solving DLP ensures the security of cryptographic protocols, making it a cornerstone of modern cryptography.

Throughout this unit, you gain a deep understanding of the mathematical foundations of cryptography. By mastering Number Theory concepts, learners develop the skills to analyze and implement secure cryptographic algorithms and protocols. This knowledge enables you to appreciate the importance of Number Theory in ensuring confidentiality, integrity, and authenticity of data.

The significance of Number Theory in cryptography extends beyond theoretical concepts. It has real-world implications for secure communication, data protection, and digital signatures. As technology advances, the demand for secure and efficient cryptographic algorithms continues to grow. This unit provides you with a solid foundation in Number Theory, empowering you to contribute to the development of secure cryptographic solutions.

In conclusion, this course unit provides a comprehensive exploration of Number Theory and its vital role in cryptography. By examining the fundamental concepts and principles of Number Theory, you gain a profound understanding of the mathematical foundations of cryptography, enabling them to develop and implement secure cryptographic algorithms and protocols.

5.0 Self-Assessment Exercise(s)

1. Describe the significance of number theory in cryptography. How do number theoretic concepts like divisibility, prime numbers, and congruences contribute to secure communication and data protection?
2. Explain the importance of Euler's Theorem, Fermat's Theorem, and the Chinese Remainder Theorem in cryptography.
3. Argue for or against the following statement: "Number theory is the foundation of modern cryptography." Provide evidence from the course material to support your position.

Answers

Exercise 1: Number theory plays a vital role in cryptography, providing the mathematical foundations for secure communication and data protection. Number theoretic concepts like divisibility, prime numbers, and congruences contribute to cryptography in several ways:

- **Divisibility:** Ensures secure key exchange and encryption, particularly in algorithms like RSA.

- Prime numbers: Used in cryptographic protocols, such as Diffie-Hellman key exchange, to ensure secure communication.
- Congruences: Enable secure encryption and decryption, particularly in modular arithmetic.

These concepts ensure confidentiality, integrity, and authenticity of data, making number theory indispensable in cryptography.

Exercise 2: Importance of Euler's Theorem, Fermat's Theorem, and Chinese Remainder Theorem.

These theorems are fundamental to cryptography:

- Euler's Theorem: Provides a way to compute modular exponentiation efficiently, ensuring secure encryption and decryption in RSA and other algorithms.
- Fermat's Theorem: Used in cryptographic protocols, such as Diffie-Hellman key exchange, to ensure secure communication.
- Chinese Remainder Theorem: Enables efficient computation of modular arithmetic, essential for cryptographic algorithms like RSA.

These theorems ensure secure data transmission, protection, and verification, making them crucial components of modern cryptography.

Exercise 3: Number Theory as the Foundation of Modern Cryptography

Argument For: Number theory is indeed the foundation of modern cryptography.

Evidence:

- Cryptographic algorithms (RSA, Diffie-Hellman, Elliptic Curve Cryptography) rely heavily on number theoretic concepts.
- Number theory provides the mathematical foundations for secure communication and data protection.
- Theorems like Euler's, Fermat's, and Chinese Remainder Theorem underpin cryptographic protocols.

Without number theory, modern cryptography would not be possible. Number theoretic concepts ensure the security and integrity of digital communication, making it the foundation of modern cryptography.

Supporting Course Material: Unit 3 (Number Theory) and Unit 4 (Roles of Cryptography in Computer and Network Security) provide comprehensive coverage of number theory's role in cryptography, reinforcing the argument that number theory is the foundation of modern cryptography.

6.0 Conclusion

In this unit, we explored the fundamental concepts of number theory and their applications in cryptography. We learned about the importance of divisibility, prime numbers, congruences, and modular arithmetic in developing secure cryptographic algorithms. We also examined the significance of Euler's Theorem, Fermat's Theorem, and the Chinese Remainder Theorem in enabling secure key exchange, digital signatures, and encryption. Through our studies, we gained a deeper understanding of how number theory provides the mathematical foundation for modern cryptography. We saw how cryptographic algorithms, such as RSA and Diffie-Hellman key exchange, rely on number theoretic concepts to ensure secure communication and data protection.

The knowledge and skills gained in this unit are essential for understanding the principles of cryptography and developing secure cryptographic systems. As we continue to rely on digital technologies to communicate and conduct transactions, the importance of cryptography and number theory will only continue to grow.

In a nutshell, this unit has provided a comprehensive introduction to the exciting and critical field of number theory and cryptography. We hope that the knowledge and skills gained will serve as a foundation for further exploration and study in this fascinating area.

7.0 Summary

This unit provided a comprehensive introduction to the fundamental concepts of number theory and their crucial applications in cryptography. It delved into the essential principles of number

theory, including divisibility, prime numbers, congruences, and modular arithmetic, which form the basis of secure cryptographic systems. The unit also explored the significant contributions of Euler's Theorem, Fermat's Theorem, Chinese Remainder Theorem e.t.c, to the development of cryptographic algorithms, such as RSA and Diffie-Hellman key exchange. By examining these concepts and their applications, the module demonstrated the critical role of number theory in ensuring the security and integrity of digital communication and data protection.

8.0 Tutor Marked Assignment

1. Write a short essay explaining the concept of congruences in number theory and how they are used in cryptography. Provide examples to illustrate your answers.
2. How does the discrete logarithm problem relate to cryptographic security?
3. What is the purpose of the Chinese Remainder Theorem in cryptography?

9.0 Further Readings

Stinson, D. R. (2005). *Cryptography: theory and practice*. Chapman and Hall/CRC.
https://almuhammadi.com/sultan/crypto_books/Stinson.3ed.pdf

Petersen, K. A. R. L. (2000). Notes on Number Theory and Cryptography.
<https://www.semanticscholar.org/paper/Notes-on-Number-Theory-and-Cryptography-Petersen/331cf92e3155b765aede69ef8e6dedc3319f5eb6>

Lenstra, A. K., & Lenstra Jr, H. W. (1990). Algorithms in number theory. In *Algorithms and complexity*(pp673-715).Elsevier.
<https://www.sciencedirect.com/science/article/abs/pii/B9780444880710500175>

UNIT 4: Roles of Cryptography in Computer and Network Security

Contents

1.0 Introduction

2.0 Intended Learning Outcomes

3.0 Basic Applications of Cryptography

3.1 Applications of Cryptography in Computer Security

3.2 Applications of Cryptography in Network Security

3.3 Cryptographic applications in emerging technologies

4.0 Discussion

5.0 Self-Assessment Exercise(s)

6.0 Conclusion

7.0 Summary

8.0 Tutor Marked Assignment

9.0 Further Readings

1.0 Introduction

Cryptography plays a vital role in ensuring the security and integrity of computer systems and networks. By harnessing the power of advanced mathematical algorithms, cryptography protects digital information from unauthorized access, use, and disruption. Through encryption, digital signatures, and other cryptographic techniques, sensitive data are shielded from cyber threats, and secure communication is enabled. In today's interconnected world, the roles of cryptography in computer and network security are multifaceted and essential, safeguarding everything from online transactions to online communications. As technology advances, the importance of cryptography will only continue to grow, making it an indispensable component of modern computer and network security.

2.0 Intended Learning Outcomes

- Understand the fundamental concepts of cryptography in computer and network security.

- Familiarity with secure communication protocols, authentication and access control methods, data protection techniques, and network security protocol
- Understand how cryptographic concepts are applied to real-world scenarios in computer and network security.

3.0 Basic Applications of Cryptography

At the core of cryptography are several fundamental applications that enable secure data exchange, authentication, and verification. These basic applications form the building blocks of cryptographic systems and are essential for protecting sensitive information in various contexts. By understanding these fundamental applications, individuals can harness the power of cryptography to safeguard their digital assets and maintain the confidentiality, integrity, and authenticity of their data. As mentioned earlier, the basic applications of cryptography include:

- Confidentiality: Ensuring that only authorized parties can access sensitive information.
- Authentication: Verifying the identity of users, devices, or systems.
- Integrity: Ensuring that data is not modified or tampered with during transmission or storage.
- Non-Repudiation: Ensuring that a sender cannot deny sending a message.
- Digital Signatures: Authenticating the source and integrity of a message.
- Encryption: Converting plaintext data into unreadable ciphertext.
- Decryption: Converting ciphertext back into readable plaintext

These basic applications form the foundation of cryptography and are used in various ways to secure data and communication in computer and network security.

3.1 Applications of Cryptography in Computer Security

Cryptography plays a crucial role in computer security, providing a robust defense against unauthorized access, data breaches, and cyber threats. By leveraging cryptographic techniques, computer systems can protect sensitive information, ensure secure communication, and maintain the integrity of digital assets. Some of the applications of cryptography in computer security include:

- Secure data storage: Encrypting data on hard drives, solid-state drives, and flash drives
- Secure boot mechanisms: Ensuring the integrity of firmware and operating systems
- Digital signatures: Authenticating software updates and patches
- Secure email clients: Encrypting emails and attachments
- Password management: Hashing and salting passwords for secure storage
- Secure online transactions: Encrypting sensitive data like credit card numbers and personal information.

3.2 Applications of Cryptography in Network Security

Cryptography plays a vital role in network security, providing the tools and techniques necessary to protect data from unauthorized access, use, and disruption. By examining the practical applications of cryptography in network security, will enable a deeper understanding of how to design and implement secure network systems that protect digital information from cyber threats.

Practical applications of cryptography include:

- Secure Socket Layer/Transport Layer Security (SSL/TLS): Encrypting web traffic
- Virtual Private Networks (VPNs): Encrypting and authenticating remote access to networks
- Secure Shell (SSH): Encrypting remote access to servers and networks
- IPsec: Encrypting and authenticating IP packets
- Secure email communication: Encrypting and authenticating email messages
- Network access control: Authenticating and encrypting network access

However, it should be noted that many applications of cryptography overlap between computer and network security.

Network Security Model

NETWORK SECURITY MODEL

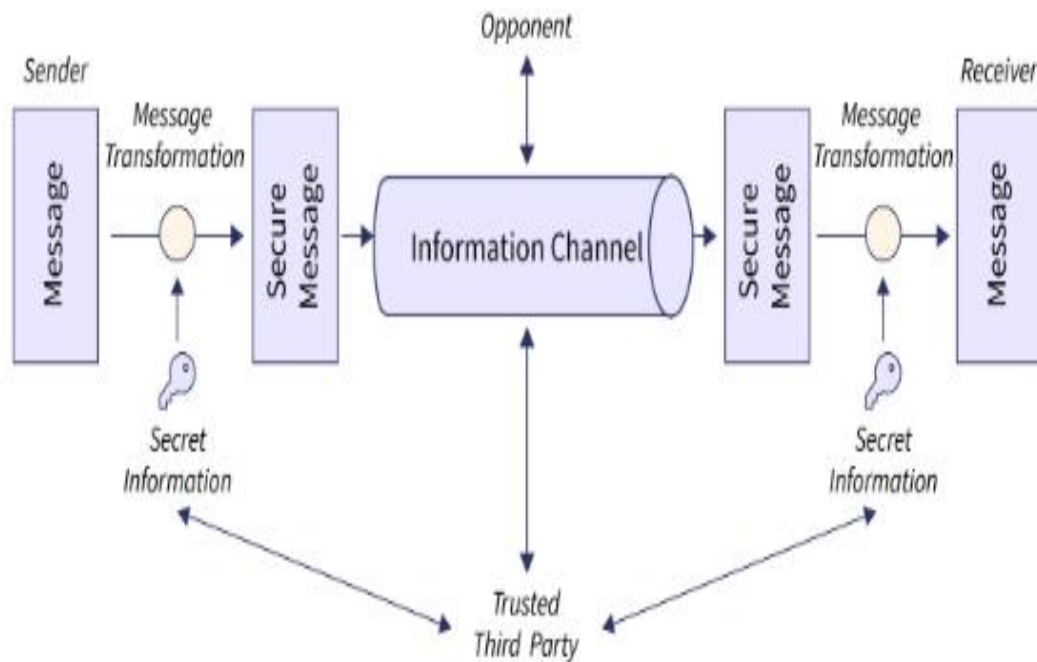

SCALER

(From <https://www.scaler.com/topics/computer-network/cryptography-and-network-security/>)

3.3 Cryptographic applications in emerging technologies (Cloud Computing, IoT, blockchain)

The rapid growth of emerging technologies such as Cloud Computing, Internet of Things (IoT), and blockchain has created a pressing need for secure and reliable data protection. Cryptography plays a vital role in these technologies, enabling secure data storage, transmission, and verification. Here, we will shed light on the vital roles of cryptography in these emerging technologies, in ensuring data confidentiality, integrity, and authenticity. The roles of cryptography in these innovative fields include:

- Cloud Computing: Secure data storage and processing in cloud infrastructure using homomorphic encryption and secure multi-party computation.
- Internet of Things (IoT): Secure communication and data protection for IoT devices using lightweight cryptography and secure protocols. Blockchain: Secure and decentralized transactions using cryptographic algorithms like public-key cryptography and hash functions.
- Artificial Intelligence (AI) and Machine Learning (ML): Secure data sharing and collaboration using homomorphic encryption and secure multi-party computation
- Quantum Computing: Post-quantum cryptography and quantum-resistant algorithms to secure against quantum computer attacks.
- 5G Networks: Secure communication and data protection using advanced cryptographic techniques like quantum-resistant algorithms and secure key management.
- Edge Computing: Secure data processing and analysis at the edge using homomorphic encryption and secure multi-party computation.

4.0 Discussion

This course unit explores the vital role of cryptography in ensuring computer and network security. Cryptography, through advanced mathematical algorithms, protects digital information from unauthorized access, use, and disruption. The unit delves into the fundamental applications of cryptography, including confidentiality, authentication, integrity, non-repudiation, digital signatures, encryption, and decryption.

Cryptography is crucial in computer security, safeguarding sensitive information, ensuring secure communication, and maintaining digital asset integrity. Applications include secure data storage, digital signatures, secure email clients, password management, and secure online transactions. In

network security, cryptography protects data from unauthorized access, use, and disruption. Practical applications include SSL/TLS, VPNs, SSH, IPsec, secure email communication, and network access control.

The unit also examines cryptography's role in emerging technologies such as cloud computing, IoT, blockchain, artificial intelligence, machine learning, quantum computing, 5G networks, and edge computing. Cryptography ensures secure data storage, transmission, and verification in these innovative fields. By mastering cryptography, individuals can design and implement secure computer and network systems, protecting digital information from cyber threats. The importance of cryptography will continue to grow as technology advances, making it an indispensable component of modern computer and network security.

Overall, this course unit provides you with a comprehensive understanding of cryptography's essential role in ensuring computer and network security, preparing learners to address the growing demand for secure and reliable data protection in today's interconnected world.

5.0 Self-Assessment Exercise(s)

1. What is the primary role of cryptography in computer and network security
2. Mention and explain the basic applications of cryptography

Answers

Exercise 1: Primary Role of Cryptography in Computer and Network Security

The primary role of cryptography in computer and network security is to protect digital information from unauthorized access, use, disruption, and cyber threats. Cryptography ensures confidentiality, integrity, authenticity, and non-repudiation of data through various techniques, including encryption, decryption, digital signatures, and secure communication protocols.

Cryptography's primary role is to:

- Secure data transmission and storage
- Protect sensitive information from unauthorized access
- Ensure authenticity and integrity of data
- Prevent data tampering and modification

- Enable secure communication and transactions

Exercise 2: Basic Applications of Cryptography

The basic applications of cryptography include:

- Confidentiality: Ensuring only authorized parties can access sensitive information.
- Authentication: Verifying the identity of users, devices, or systems.
- Integrity: Ensuring data is not modified or tampered with during transmission or storage.
- Non-Repudiation: Ensuring a sender cannot deny sending a message.
- Digital Signatures: Authenticating the source and integrity of a message.
- Encryption: Converting plaintext data into unreadable ciphertext.
- Decryption: Converting ciphertext back into readable plaintext.

These basic applications form the foundation of cryptography and are used in various ways to secure data and communication in computer and network security.

Additional applications of cryptography include:

- Secure data storage
- Secure communication protocols (SSL/TLS, VPNs, SSH)
- Secure email communication
- Password management
- Secure online transactions
- Cloud computing security
- IoT security
- Blockchain security

6.0 Conclusion

This unit has made us to understand that through its various applications, cryptography protects sensitive information from unauthorized access, use, and disruption. From secure data storage and online transactions to secure communication and authentication, cryptography is an indispensable component of modern computer and network security. As technology advances, the importance of cryptography will only continue to grow, particularly in emerging technologies like cloud

computing, IoT, blockchain, and quantum computing. Therefore, it is essential to understand the fundamental concepts and applications of cryptography in computer and network security.

By harnessing the power of cryptography, we can safeguard our digital assets and maintain the confidentiality, integrity, and authenticity of our data. In today's interconnected world, the roles of cryptography in computer and network security are multifaceted and essential, making it an exciting and critical field of study.

7.0 Summary

Cryptography plays a vital role in protecting sensitive information from unauthorized access in computer and network security. It provides various basic applications, including confidentiality, authentication, and encryption, which are essential for securing data storage, communication, and online transactions. Cryptography is crucial in computer security, network security, and emerging technologies like cloud computing, IoT, blockchain, and quantum computing, making it an essential component of modern computer and network security. Understanding cryptography is vital for individuals and organizations to safeguard their digital assets and maintain the confidentiality, integrity, and authenticity of their data.

8.0 Tutor Marked Assignment

1. What are the fundamental concepts of cryptography that enable secure data exchange, authentication, and verification in computer and network security?
2. Describe the applications of cryptography in computer security, including secure data storage, boot mechanisms, email, password management, and online transactions.
3. Explain the role of cryptography in emerging technologies such as cloud computing, IoT, blockchain, and quantum computing. How do cryptographic techniques enable secure data storage, transmission, and verification in these innovative fields?

9.0 Further Readings

Geetha, V., Singh, P., Patil, N. S., & Reddy, S. S. S. (2023). *Introduction To Cryptography And Network Security*. AG PUBLISHING HOUSE (AGPH Books).

<https://www.flipkart.com/introduction-cryptography-network-security/p/itmfa58534089?pid=9788119025756>

Rizvi, Q. M., & Kushwaha, R. S. (2023). EXPLORING MODERN CRYPTOGRAPHY: A COMPREHENSIVE GUIDE TO TECHNIQUES AND APPLICATIONS. *International Research Journal of Modernization in Engineering Technology and Science*, 5(05), 2582-5208. https://www.researchgate.net/publication/318200344_Cryptography_A_Comparative_Analysis_for_Modern_Techniques

Singh, B., Ahateshaam, M., Lahiri, A., & Sagar, A. K. (2023, August). Future of Cryptography in the Era of Quantum Computing. In *International Conference on Electrical and Electronics Engineering* (pp. 13-31). Singapore: Springer Nature Singapore. <https://www.springerprofessional.de/en/future-of-cryptography-in-the-era-of-quantum-computing/26744606>

Module 2: Types of cryptography

Introduction

As stated earlier, Module 2 builds on the foundational knowledge from Module 1, delving deeper into the world of cryptography. This module explores the different types of cryptography and helps in creating in-depth understanding of the concepts of secret keys, which are crucial for secure communication. You will learn about fundamental concepts such as Block Ciphers, Stream Ciphers, and Data Encryption.

Unit 1: Symmetric Cryptography

Unit 2: Classical Cryptography

Unit 3: Block Ciphers (Data Encryption Standards, AES, Mode of operations)

Unit 4: Stream Ciphers (Concept, Advantages, and Disadvantages)

UNIT 1: Symmetric Cryptography

Contents

- 1.0 Introduction
- 2.0 Intended Learning Outcomes
- 3.0 Basic Concept of Symmetric Cryptography
 - 3.1 Symmetric Encryption Algorithms
 - 3.2 Symmetric Key Management and Security
- 4.0 Discussion
- 5.0 Self-Assessment Exercise(s)
- 6.0 Conclusion
- 7.0 Summary
- 8.0 Tutor Marked Assignment
- 9.0 Further Readings

1.0 Introduction

This unit will provide a comprehensive understanding of Symmetric Cryptography, exploring its intricacies through various themes. By delving into the two main types of symmetric algorithms, Block Ciphers and Stream Ciphers, you will gain a deeper understanding of how they work and their respective advantages and limitations.

Moreover, this unit will also cover key management and security, which are crucial aspects of symmetric cryptography. You will learn about key generation, distribution, storage, and exchange. Additionally, you will also explore the security threats associated with symmetric keys. By the end of this unit, you will have a solid understanding of symmetric cryptography, its algorithms, and key management, preparing you for more advanced topics in cryptography.

2.0 Intended Learning outcomes

- Understand the principles and mechanisms of symmetric encryption algorithms.
- Analyze and evaluate the security strengths and weaknesses of symmetric key management, including key generation, distribution, storage, and exchange.

3.0 Basic Symmetric Cryptography

Symmetric cryptography, also known as symmetric-key cryptography, is a type of cryptography that uses the same key for both encryption and decryption. This means that the key used to encrypt

the data is the same key used to decrypt it. Symmetric cryptography is fast, efficient, and widely used in various applications, including data encryption, digital signatures, and secure communication protocols.

In symmetric cryptography, the encryption and decryption processes are inverse operations, where the encryption algorithm uses the key to transform plaintext data into ciphertext, and the decryption algorithm uses the same key to transform the ciphertext back into plaintext. The security of symmetric cryptography relies on the secrecy of the key, as an unauthorized party with access to the key can easily decrypt the data. Here symmetric cryptography will be discussed under two major themes which are;

- Symmetric Encryption Algorithms
- Symmetric Key Management and Security

3.1 Symmetric Encryption Algorithms

As earlier mentioned in this unit, symmetric encryption algorithms use the same key for both encryption and decryption. These algorithms are fast, efficient, and widely used in various applications. In continuation of this discussion, we will explore two types of symmetric encryption algorithms: Block Ciphers and Stream Ciphers.

- Block Ciphers

Block ciphers encrypt data in fixed-length blocks, typically 64 or 128 bits. The same key is used for both encryption and decryption. Popular block ciphers include:

- Advanced Encryption Standard (AES)
- Data Encryption Standard (DES)
- Triple Data Encryption Algorithm (3DES)

AES is the most widely used block cipher, known for its security and efficiency.

- Stream Ciphers

Stream ciphers encrypt data in a continuous stream, one bit or byte at a time. The key is constantly changing, making it more secure than block ciphers. Popular stream ciphers include:

- RC4 (Rivest Cipher 4)
- FISH (Fast and Secure Hash)
- Salsa20

RC4 is a widely used stream cipher, but it has security vulnerabilities and is no longer recommended.

In a nutshell, symmetric encryption algorithms are fast and efficient, making them suitable for large-scale data encryption. Block ciphers like AES are widely used, while stream ciphers like RC4 are less popular due to security concerns. Understanding symmetric encryption algorithms is crucial for secure data protection.

Working Principle of Symmetric Encryption.

How Symmetric Encryption Works

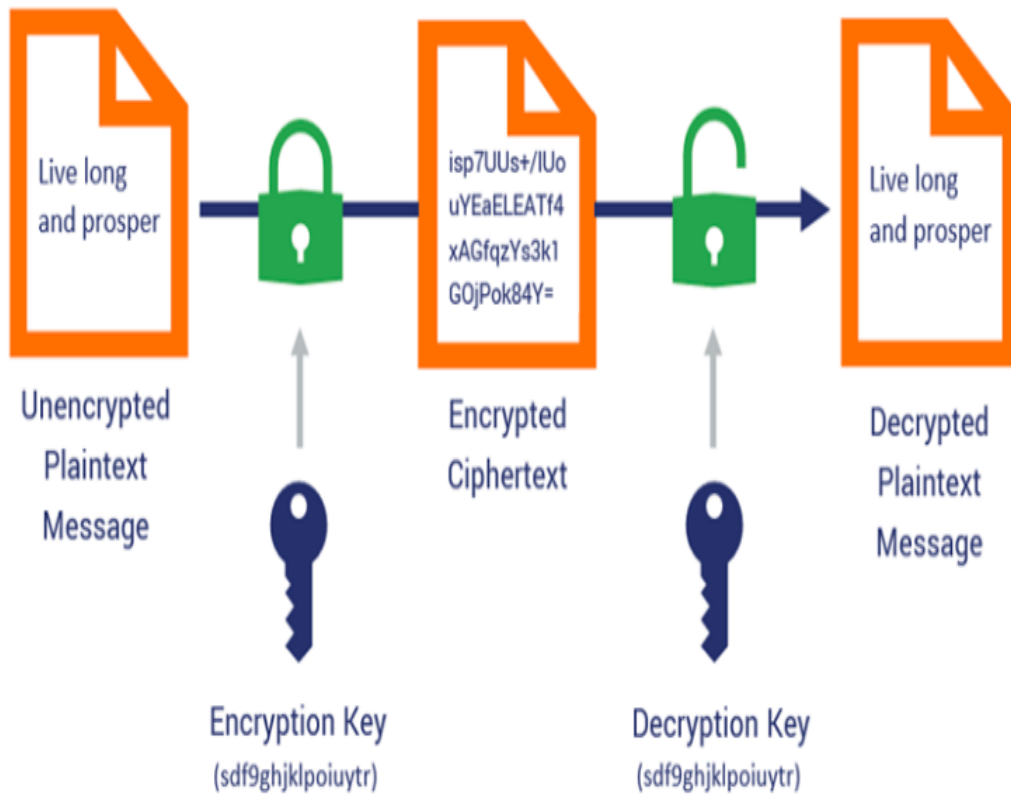

(From <https://www.thesslstore.com/blog/symmetric-encryption-algorithms/>)

3.2 Symmetric Key Management and Security

Symmetric key management is critical to ensure the security of symmetric encryption algorithms. Key management involves generating, distributing, storing, and revoking symmetric keys. Proper key management is essential to prevent unauthorized access and ensure data confidentiality, integrity, and authenticity.

- **Key Generation**

Symmetric keys are generated randomly and securely, using a cryptographically secure pseudorandom number generator (CSPRNG).

- **Key Distribution**

Symmetric keys should be distributed securely, using a secure key exchange protocol, such as Diffie-Hellman or RSA.

- **Key Storage**

Symmetric keys should be stored securely, using a secure key storage solution, such as a Hardware Security Module (HSM) or a secure key vault.

- **Key Revocation**

Symmetric keys should be revoked and replaced regularly, to prevent key compromise and unauthorized access.

- **Key Security Threats**

Symmetric keys are vulnerable to various security threats, which can be categorized as one of the following: Brute force attacks, Side-channel attacks, Key compromise attacks and aMan-in-the-middle attacks.

- **Key Management Best Practices**

To ensure symmetric key security, follow these best practices:

- Use secure key generation and distribution methods

- Store keys securely and limit access
- Rotate and revoke keys regularly
- Monitor key usage and detect anomalies
- Use secure protocols and algorithms

In summary, symmetric key management and security are critical components of symmetric encryption. Proper key management and security measures can prevent unauthorized access and ensure data confidentiality, integrity, and authenticity.

4.0 Discussion

This unit provides a comprehensive understanding of symmetric cryptography, exploring its principles, mechanisms, and applications. Symmetric cryptography uses the same key for encryption and decryption, offering fast and efficient data protection. The unit delves into symmetric encryption algorithms, including block ciphers and stream ciphers, highlighting their advantages and limitations.

Block ciphers, such as Advanced Encryption Standard (AES), Data Encryption Standard (DES), and Triple Data Encryption Algorithm (3DES), encrypt data in fixed-length blocks. Stream ciphers, like RC4, FISH, and Salsa20, encrypt data in a continuous stream. Understanding these algorithms is crucial for secure data protection. Also, symmetric key management is critical to ensure the security of symmetric encryption algorithms. Key management involves generating, distributing, storing, and revoking symmetric keys. Proper key management prevents unauthorized access and ensures data confidentiality, integrity, and authenticity.

Key generation involves using cryptographically secure pseudorandom number generators. Key distribution requires secure key exchange protocols, such as Diffie-Hellman or RSA. Key storage solutions include Hardware Security Modules (HSMs) or secure key vaults. Regular key revocation and rotation prevent key compromise.

Symmetric keys are vulnerable to brute force attacks, side-channel attacks, key compromise attacks, and man-in-the-middle attacks. Best practices for key management include secure key generation and distribution; secure storage, regular rotation and revocation, monitoring key usage, and using secure protocols and algorithms.

Symmetric cryptography's advantages include speed and efficiency, making it suitable for large-scale data encryption. However, limitations include key management issues and vulnerability to brute force attacks. Understanding symmetric cryptography is essential for data security and confidentiality, and it's widely used in various applications, including data encryption, digital signatures, and secure communication protocols.

By mastering symmetric cryptography, individuals can appreciate its importance in ensuring data confidentiality, integrity, and authenticity, preparing them to explore more advanced topics in cryptography, such as asymmetric cryptography and public-key infrastructure.

5.0 Self-Assessment Exercise(s)

1. Explain the importance of symmetric key management and security. Discuss the key generation, distribution, storage, and revocation processes, and highlight the security threats associated with symmetric keys.
2. Compare and contrast block ciphers and stream ciphers. Describe their differences and similarities, and explain the scenarios in which each is suitable.

Answers

Exercise 1: Importance of Symmetric Key Management and Security

Symmetric key management and security are crucial components of symmetric cryptography, ensuring the confidentiality, integrity, and authenticity of encrypted data. Effective key management involves:

- **Key Generation:** Generating symmetric keys randomly and securely using cryptographically secure pseudorandom number generators (CSPRNGs).
- **Key Distribution:** Distributing symmetric keys securely using secure key exchange protocols, such as Diffie-Hellman or RSA.
- **Key Storage:** Storing symmetric keys securely using Hardware Security Modules (HSMs) or secure key vaults.
- **Key Revocation:** Revoking and replacing symmetric keys regularly to prevent key compromise.

Security threats associated with symmetric keys include:

- Brute force attacks
- . Side-channel attacks
- Key compromise attacks
- Man-in-the-middle attacks

Exercise 2: Comparison of Block Ciphers and Stream Ciphers

Block ciphers and stream ciphers are symmetric encryption algorithms used to protect data.

Similarities:

- Both use symmetric keys for encryption and decryption.
- Both ensure data confidentiality and integrity.

Differences:

- Encryption Method:
While block ciphers encrypt data in fixed-length blocks, stream ciphers encrypt data in a continuous stream (one bit/byte at a time).
- Key Usage:
Block ciphers use the same key for each block while stream ciphers constantly change the key.
- Security:
Block ciphers (e.g., AES) are generally more secure, stream ciphers (e.g., RC4) are vulnerable to attacks.
- Performance:
Block ciphers are slower due to block processing while stream ciphers are faster due to continuous encryption.

Scenarios for each cipher usage:

Block Ciphers are suitable for:

- Large-scale data encryption

- High-security applications (financial, government)
- Data at rest encryption

Stream Ciphers are suitable for:

- Real-time data encryption (voice, video)
- Low-latency applications
- Resource-constrained devices

6.0 Conclusion

Symmetric cryptography is a fundamental building block of modern cryptography, providing a secure and efficient way to protect data. Through this unit, we have explored the principles and mechanisms of symmetric encryption algorithms, including block ciphers and stream ciphers. We have also delved into the critical aspects of symmetric key management and security, including key generation, distribution, storage, and revocation.

Symmetric cryptography is widely used in various applications, including data encryption, digital signatures, and secure communication protocols. Its advantages, such as speed and efficiency, make it an essential tool for large-scale data encryption. However, symmetric cryptography also has its limitations, including key management issues and vulnerability to brute force attacks.

By understanding the concepts and techniques presented in this unit, you are now equipped to appreciate the importance of symmetric cryptography in ensuring data confidentiality, integrity, and authenticity. You are also prepared to explore more advanced topics in cryptography, such as asymmetric cryptography and public-key infrastructure. In the next unit, we will build upon the foundation established here and explore the principles and applications of asymmetric cryptography.

7.0 Summary

Symmetric cryptography uses the same key for encryption and decryption, offering fast and efficient data protection. However, key management is crucial, involving secure key generation, distribution, storage, and revocation. Block ciphers, like AES, and stream ciphers, like RC4, are used, but symmetric cryptography is vulnerable to brute force attacks and key compromise.

Understanding symmetric cryptography is essential for data security and confidentiality, and it's widely used in various applications.

8.0 Tutor Marked Assignment

1. Explain the differences between block ciphers and stream ciphers, highlighting their respective advantages and disadvantages. Provide examples of each type of cipher and discuss their use cases.
2. Suppose you are a cybersecurity consultant tasked with securing a company's sensitive data. Describe a symmetric key management system you would implement, including key generation, distribution, storage, and revocation processes.

9.0 Further Readings

Boneh, D., & Shoup, V. (2020). A graduate course in applied cryptography. *Draft 0.5*. https://crypto.stanford.edu/~dabo/cryptobook/BonehShoup_0_5.pdf

Boura, C., & Naya-Plasencia, M. (Eds.). (2023). *Symmetric Cryptography, Volume 1: Design and Security Proofs*. John Wiley & Sons. <https://www.wiley.com/en-ca/Symmetric+Cryptography%2C+Volume+1%3A+Design+and+Security+Proofs-p-9781789451467>

Perrin, L. (2024). New Fields in Symmetric Cryptography. *Symmetric Cryptography, Volume 2: Cryptanalysis and Future Directions*, 215. <https://www.wiley.com/en-ca/Symmetric+Cryptography%2C+Volume+1%3A+Design+and+Security+Proofs-p-9781789451467>

UNIT 2: Classical Cryptography

Contents

- 1.0 Introduction
- 2.0 Intended Learning Outcomes
- 3.0 Classical Cryptography
 - 3.1 Substitution Techniques
 - 3.2 Transposition Techniques
- 4.0 Discussion
- 5.0 Self-Assessment Exercise(s)
- 6.0 Conclusion
- 7.0 Summary
- 8.0 Tutor Marked Assignment
- 9.0 Further Readings

1.0 Introduction

This course unit further explores the fundamental concepts that have shaped the field. This unit will take you on a journey through the evolution of cryptography, from ancient civilizations to modern times, covering various techniques and methods used to secure communication. We will also examine famous cryptographic systems, like the Caesar Ciphers, and discuss their strengths and weaknesses.

Therefore, this unit will equip you with deep understanding of the classical cryptography concepts that laid the groundwork for modern cryptography, enabling you to appreciate the development of secure communication methods and their applications in today's digital world.

2.0 Intended Learning Outcomes

1. Understand the fundamental principles of classical cryptography
2. Analyze and apply classical encryption algorithms
3. Evaluate the security and limitations of classical cryptographic systems

3.0 Classical Cryptography

Classical cryptography laid the foundation for modern cryptography, which uses complex algorithms and computer processing power to secure digital communication. Classical cryptography refers to ancient and historical methods of secure communication, used before the modern computer era. These techniques used pen and paper, relying on human ingenuity and cleverness to secure messages. Thus it rely on manual techniques to encrypt and decrypt messages, ensuring confidentiality and security. Classical cryptography includes:

- Substitution (e.g., Caesar Cipher)
- Transposition (e.g., Rail Fence Cipher, Columnar Transposition)

Diagram showing Classical Cryptography as a major type of Cipher in Cryptography

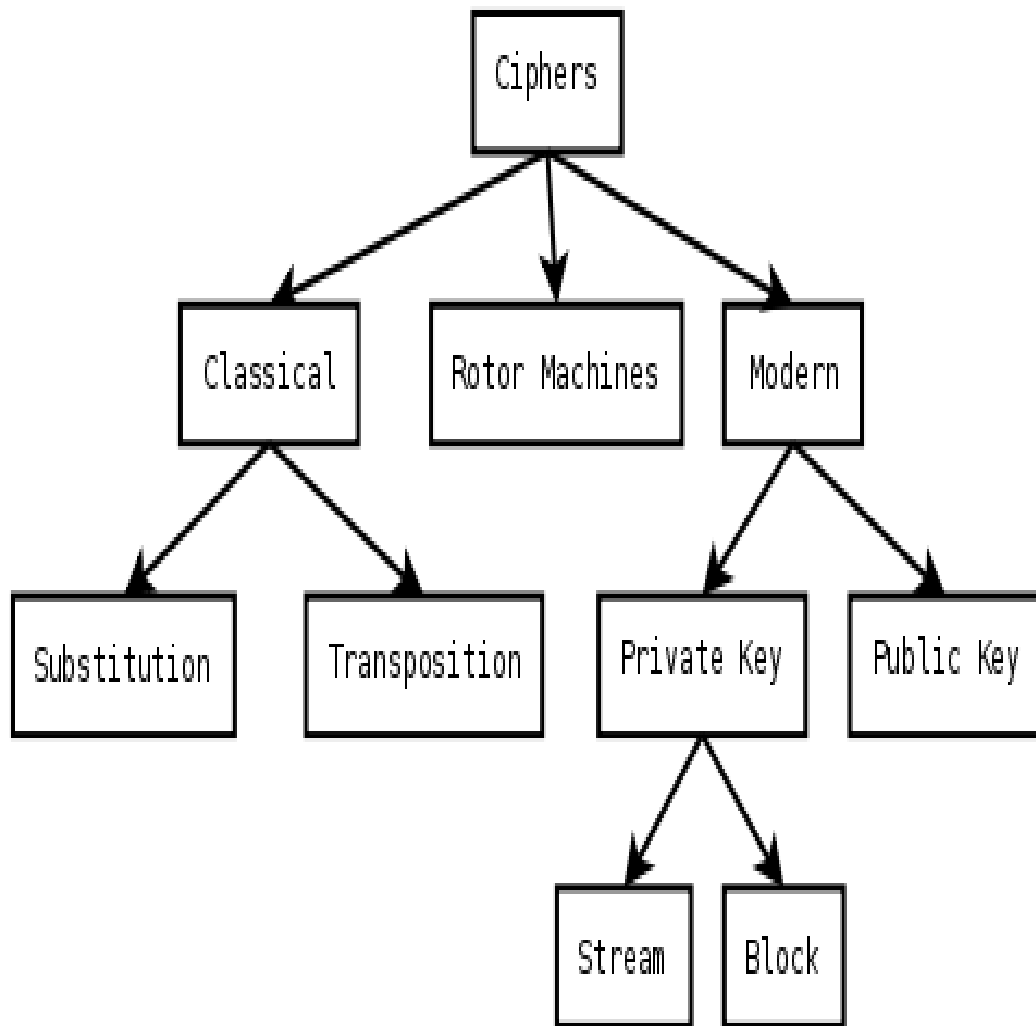

3.1 Substitution Technique

Substitution techniques in classical cryptography involve replacing plaintext letters or symbols with other letters or symbols to create a ciphertext. Here are some common substitution techniques

- i. Caesar Cipher: Shifts each letter by a fixed number of positions in the alphabet.
- ii. Monoalphabetic Substitution: Replaces each letter with a different letter or symbol, using a fixed substitution table.
- iii. Polyalphabetic Substitution: Uses multiple substitution tables or keys to replace letters, making it more secure than monoalphabetic substitution.
- iv. Homophonic Substitution: Replaces each letter with a different letter or symbol that sounds similar when spoken.
- v. . Letter-Number Substitution: Replaces letters with corresponding numbers or symbols.

Substitution techniques are simple to implement but have limitations, as they can be vulnerable to frequency analysis attacks, where an attacker exploits the frequency of letters in the language to decipher the message. These techniques were used in ancient civilizations, such as the Egyptians and Greeks, to secure messages, and laid the foundation for more advanced cryptographic methods.

Transposition Techniques

Transposition techniques in classical cryptography involve rearranging the letters of the plaintext to create a ciphertext, without substituting letters. Instead, the letters are reordered according to a specific pattern or algorithm. This technique requires a fixed-length plaintext and a predetermined key or pattern to rearrange the letters. There are several types of transposition techniques, these include:

- i. Rail Fence Cipher: Writes the plaintext in a zigzag pattern along a series of "rails" and then reads off the ciphertext along the rails.
- ii. Columnar Transposition: Writes the plaintext in columns and then rearranges the columns according to a key.
- iii. Permutation Cipher: Rearranges the letters according to a specific permutation.

Transposition techniques are more secure than substitution techniques because they don't rely on frequent letter patterns. However, they can be vulnerable to attacks if the key or pattern is not

secure. Transposition techniques were used in ancient civilizations, such as the Spartans, to secure messages. Additionally, these techniques require a deeper understanding of mathematical concepts, such as permutations and combinations, and are more complex than substitution techniques. Despite their limitations, transposition techniques played a significant role in the development of cryptography and are still used in modern cryptographic algorithms, such as the Advanced Encryption Standard (AES).

4.0 Discussion

This unit provides a comprehensive understanding of symmetric cryptography, exploring its principles, mechanisms, and applications. Symmetric cryptography uses the same key for encryption and decryption, offering fast and efficient data protection. The unit delves into symmetric encryption algorithms, including block ciphers and stream ciphers, highlighting their advantages and limitations. Block ciphers, such as Advanced Encryption Standard (AES), Data Encryption Standard (DES), and Triple Data Encryption Algorithm (3DES), encrypt data in fixed-length blocks. Stream ciphers, like RC4, FISH, and Salsa20, encrypt data in a continuous stream. Understanding these algorithms is crucial for secure data protection.

Symmetric key management is critical to ensure the security of symmetric encryption algorithms. Key management involves generating, distributing, storing, and revoking symmetric keys. Proper key management prevents unauthorized access and ensures data confidentiality, integrity, and authenticity.

Key generation involves using cryptographically secure pseudorandom number generators. Key distribution requires secure key exchange protocols, such as Diffie-Hellman or RSA. Key storage solutions include Hardware Security Modules (HSMs) or secure key vaults. Regular key revocation and rotation prevent key compromise. Symmetric keys are vulnerable to brute force attacks, side-channel attacks, key compromise attacks, and man-in-the-middle attacks. Best practices for key management include secure key generation and distribution, secure storage, regular rotation and revocation, monitoring key usage, and using secure protocols and algorithms.

Symmetric cryptography's advantages include speed and efficiency, making it suitable for large-scale data encryption. However, limitations include key management issues and vulnerability to brute force attacks. Understanding symmetric cryptography is essential for data security and

confidentiality, and it's widely used in various applications, including data encryption, digital signatures, and secure communication protocols. By mastering symmetric cryptography, individuals can appreciate its importance in ensuring data confidentiality, integrity, and authenticity, preparing them to explore more advanced topics in cryptography, such as asymmetric cryptography and public-key infrastructure.

5.0 Self-Assessment Exercise(s)

1. Identify and describe the three main types of substitution techniques in classical cryptography
2. Compare and contrast substitution and transposition techniques in classical cryptography. How do they differ, and what are the advantages and disadvantages of each?

Answers

Exercise 1: Three Main Types of Substitution Techniques in Classical Cryptography

In classical cryptography, substitution techniques replace plaintext elements (letters or symbols) with other elements to create ciphertext. The three main types of substitution techniques are:

- **Monoalphabetic Substitution:** This technique replaces each plaintext letter with a fixed corresponding ciphertext letter. An example is the Caesar Cipher, where each letter is shifted by a fixed number of positions.
- **Polyalphabetic Substitution:** This technique replaces each plaintext letter with multiple corresponding ciphertext letters, depending on the key. An example is the Vigenère Cipher, which uses a keyword to determine the substitution.
- **Homophonic Substitution:** This technique replaces each plaintext letter with multiple corresponding ciphertext letters, making frequency analysis more difficult. An example is the Navajo Code, which uses multiple symbols to represent a single letter.

Exercise 2: Comparison of Substitution and Transposition Techniques

Substitution Techniques are techniques used to replace plaintext elements with other elements.

Advantages:

- Easy to implement

- Fast encryption and decryption
- Can be combined with other techniques

Disadvantages:

- Vulnerable to frequency analysis
- Limited security

Transposition Techniques are techniques used to rearrange plaintext elements.

Advantages:

- More secure than substitution techniques
- Resistant to frequency analysis
- Can be combined with substitution techniques

Disadvantages:

- More complex to implement
- Slower encryption and decryption
- Requires more key information

Key Differences:

- Substitution replaces elements, while transposition rearranges them.
- Substitution is vulnerable to frequency analysis, while transposition is resistant.
- Transposition requires more key information and is more complex.

In summary, substitution techniques are simpler and faster but less secure, while transposition techniques are more secure but more complex and slower. Combining both techniques can provide a more robust encryption system.

6.0 Conclusion

This unit on Classical Cryptography has provided a comprehensive overview of the fundamental principles and techniques that shaped the field of cryptography. We have explored the evolution of cryptography from ancient civilizations to modern times, including various substitution and transposition techniques. Through this unit, we have gained a deep understanding of how classical cryptography laid the foundation for modern cryptography, enabling us to appreciate the development of secure communication methods and their applications in today's digital world. We have analyzed and applied classical encryption algorithms, evaluated their security and limitations, and recognized the importance of cryptography in ensuring confidentiality, integrity, and authenticity of information. This knowledge will serve as a solid foundation for further exploration of modern cryptography and its applications in various fields.

7.0 Summary

This unit on Classical Cryptography covered the fundamental principles and techniques of cryptography used before the modern computer era. Manual techniques, such as substitution and transposition, were used to secure messages. Substitution techniques replaced plaintext letters with other letters or symbols, while transposition techniques rearranged letters according to a specific pattern. Although simple, these techniques have limitations and vulnerabilities to frequency analysis attacks. Despite this, they played a significant role in the development of cryptography and are still used in modern algorithms.

Moreover, this understanding of classical cryptography's foundation has allowed us to appreciate the development of secure communication methods and their modern applications. The knowledge gained from this unit will serve as a solid foundation for further exploration of modern cryptography and its various field applications.

8.0 Tutor Marked Assignment

1. Explain the principles of substitution and transposition techniques in classical cryptography. Provide examples of each and discuss their strengths and weaknesses.
2. Analyze and compare the security features of the Caesar Cipher and the Vigenère Cipher. How do they differ, and what are the advantages and disadvantages of each?

9.0 Further Readings

Rajasekar, V., Premalatha, J., Dhanaraj, R. K., & Geman, O. (2022). Introduction to Classical Cryptography. *Quantum Blockchain: An Emerging Cryptographic Paradigm*, 1-29. <https://www.wiley.com/enes/Quantum+Blockchain%3A+An+Emerging+Cryptographic+Paradigm-p-00356301>

Banoth, R., & Regar, R. (2023). An Introduction to Classical and Modern Cryptography. In *Classical and Modern Cryptography for Beginners* (pp. 1-46). Cham: Springer Nature Switzerland. https://www.researchgate.net/publication/371839826_Classical_and_Modern_Cryptography_for_Beginners

Vaudenay, S. (2005). *A classical introduction to cryptography: Applications for communications security*. Springer Science & Business Media. <https://link.springer.com/book/10.1007/b136373>

Banoth, R., & Regar, R. (2023). *Classical and Modern Cryptography for Beginners* (pp. 1-215). Springer. https://www.researchgate.net/publication/371839826_Classical_and_Modern_Cryptography_for_Beginners

UNIT 3: Modern Block Ciphers

Contents

1.0 Introduction

2.0 Intended Learning Outcomes

3.0 Modern Block Ciphers

3.1 Principles of Modern Block Ciphers

3.2 Data Encryption Standards (DES)

3.3 Advanced Encryption Standard (AES)

4.0 Discussion

5.0 Self-Assessment Exercise(s)

6.0 Conclusion

7.0 Summary

8.0 Tutor Marked Assignment

9.0 Further Readings

1.0 Introduction

Introduction to Modern Block Ciphers is a course unit that explores the fundamental principles and techniques of modern symmetric encryption algorithms. Students will learn about the design and analysis of block ciphers, including the Advanced Encryption Standard (AES) and other modern block ciphers.

Through discussions, and hands-on exercises, students will gain a deep understanding of modern block ciphers and their applications in secure data storage and communication. By the end of this unit, students will be able to analyze and evaluate the security and performance of modern block ciphers, preparing them for advanced studies in cryptography and cybersecurity.

2.0 Intended Learning Outcomes

1. Analyze the design principles and security properties of modern block ciphers, including substitution-permutation networks, confusion, diffusion, and avalanche effect.
2. Evaluate the security strengths and weaknesses of various block cipher modes of operation, such as ECB, CBC, and GCM, and choose appropriate modes for different applications.
3. Implement and optimize block cipher algorithms, including AES, using programming languages and cryptographic libraries, and measure their performance in terms of speed and security.
4. Compare and contrast different modern block ciphers, including their architectures, key sizes, and resistance to various attacks, such as differential and side-channel attacks, and recommend appropriate ciphers for specific use cases.

4.0 Modern Block Ciphers

Modern block ciphers are symmetric encryption algorithms that encrypt data in fixed-size blocks, typically 64 or 128 bits. They are widely used in various applications, including data storage, network communication, and cloud security. The most popular modern block cipher is the Advanced Encryption Standard (AES), adopted in 2001. AES is a substitution-permutation network (SPN) that uses a key size of 128, 192, or 256 bits and encrypts data in 10, 12, or 14 rounds. Other modern block ciphers include the Data Encryption Standard (DES), Triple DES (3DES), and the International Data Encryption Algorithm (IDEA). These ciphers have been used in various applications, but AES has largely replaced them due to its superior security and performance.

Modern block ciphers are designed to provide confidentiality, integrity, and authenticity of data. They are resistant to various attacks, including differential and linear cryptanalysis, and are optimized for software and hardware implementations. The security of modern block ciphers depends on the key size, number of rounds, and mode of operation. The most commonly used modes are Electronic Codebook (ECB), Cipher Block Chaining (CBC), and Galois/Counter Mode (GCM). Modern block ciphers are symmetric encryption algorithms that encrypt data in fixed-size blocks, typically 64 or 128 bits. They are widely used in various applications, including data storage, network communication, and cloud security. The most popular modern block cipher is the Advanced Encryption Standard (AES), adopted in 2001. AES is a substitution-permutation network (SPN) that uses a key size of 128, 192, or 256 bits and encrypts data in 10, 12, or 14

rounds. Other modern block ciphers include the Data Encryption Standard (DES), Triple DES (3DES), and the International Data Encryption Algorithm (IDEA). These ciphers have been used in various applications, but AES has largely replaced them due to its superior security and performance.

Modern block ciphers are designed to provide confidentiality, integrity, and authenticity of data. They are resistant to various attacks, including differential and linear cryptanalysis, and are optimized for software and hardware implementations. The security of modern block ciphers depends on the key size, number of rounds, and mode of operation. The most commonly used modes are Electronic Codebook (ECB), Cipher Block Chaining (CBC), and Galois/Counter Mode (GCM).

3.1 Principles of Modern Block Ciphers

Modern block ciphers operate on the principle of confusion and diffusion, which ensures that the ciphertext is unpredictable and irreversibly transformed from the plaintext. Confusion is achieved through substitution, where each plaintext bit is replaced by a different bit, making it difficult to deduce the original value. Diffusion, on the other hand, spreads the plaintext bits across the block, making it hard to trace the original bit positions.

The substitution-permutation network (SPN) is a common architecture used in modern block ciphers, including AES. The SPN consists of multiple rounds, each comprising:

- i. Substitution: Plaintext bits are replaced using a substitution table (S-box).
- ii. Permutation: Bits are rearranged according to a fixed pattern.
- iii. Key addition: Round keys are added to the plaintext.

This process is repeated for multiple rounds, ensuring that each plaintext bit influences the entire ciphertext block. The key size and number of rounds determine the cipher's security strength. Modern block ciphers also use modes of operation, such as ECB, CBC, and GCM, to enhance security and integrity. These principles and architectures work together to ensure the confidentiality, integrity, and authenticity of data encrypted using modern block ciphers.

Block Cipher

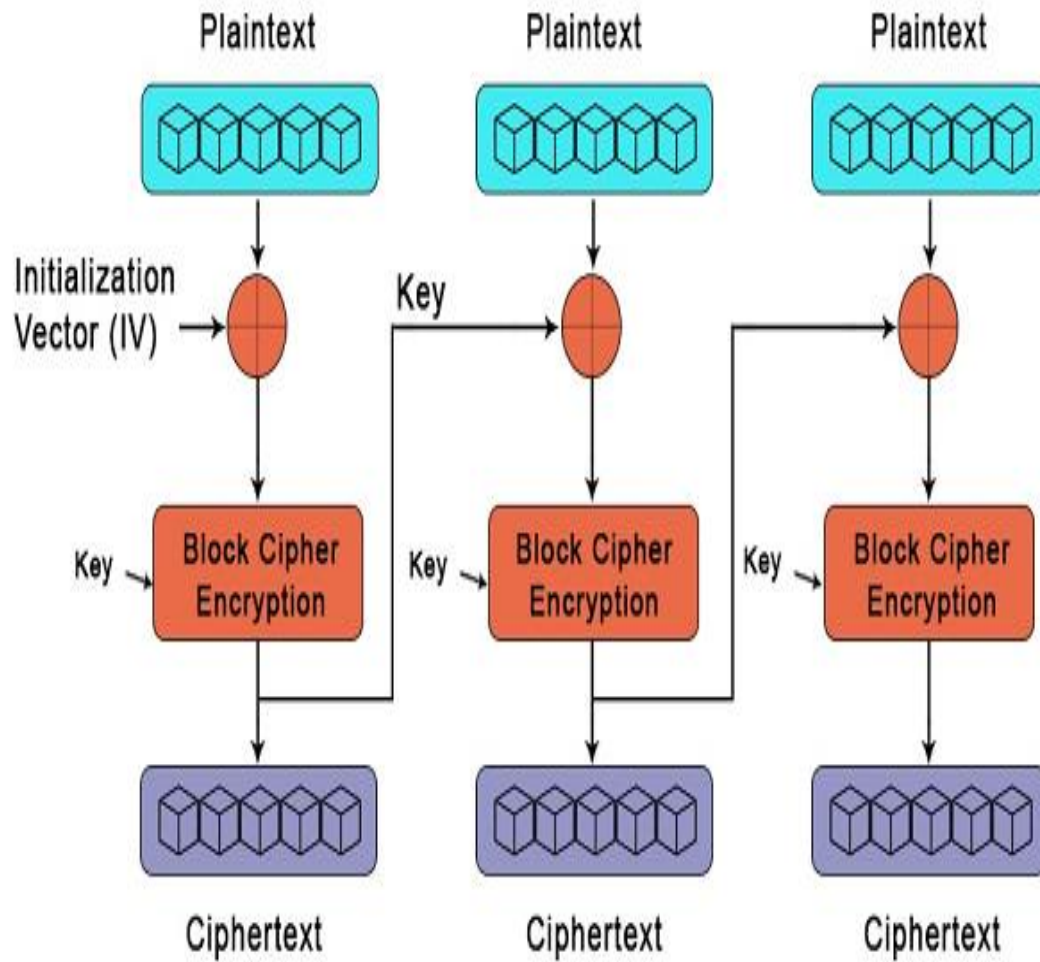

(From <https://www.javatpoint.com/block-cipher-vs-stream-cipher>)

3.2 Data Encryption Standards (DES)

The Data Encryption Standard (DES) is a symmetric-key block cipher that was widely used for encrypting electronic data. Developed in the 1970s and adopted as a federal standard in 1977, DES was designed to provide secure data encryption for organizations. It uses a 56-bit key and encrypts data in 64-bit blocks, utilizing a substitution-permutation network (SPN) architecture. However, DES has several limitations and vulnerabilities that make it insecure for modern use. One major issue is its short key length, which makes it susceptible to brute-force attacks. Additionally, DES uses a simple permutation table, making it vulnerable to differential cryptanalysis attacks. As a result, DES has been deprecated and replaced by more secure algorithms like AES. Despite its limitations, DES played a significant role in the development of modern cryptography and served as a foundation for later encryption algorithms. Its legacy continues to influence encryption techniques, and it remains an important historical milestone in the evolution of data security.

3.3 Advanced Encryption Standard (AES)

The Advanced Encryption Standard (AES) is a modern block cipher that encrypts data in 128-bit blocks using a symmetric key. AES is a substitution-permutation network (SPN) that uses a key size of 128, 192, or 256 bits and encrypts data in 10, 12, or 14 rounds, respectively. Each round consists of four operations:

- i. SubBytes: Byte substitution using a lookup table (S-box).
- ii. ShiftRows: Row-wise permutation of bytes.
- iii. MixColumns: Column-wise mixing of bytes.
- iv. AddRoundKey: XOR operation with the round key.

AES is designed to be fast, secure, and efficient in both software and hardware implementations. It is widely used in various applications, including data storage, network communication, and cloud security. AES is resistant to various attacks, including differential and linear cryptanalysis, and is considered secure for encrypting sensitive data. The AES algorithm is publicly available and has been extensively tested and validated by the cryptographic community, making it a trusted and widely adopted encryption standard.

4.0 Discussion

This course provides a comprehensive introduction to cryptography, exploring its fundamental concepts, principles, and techniques. Cryptography, the practice and study of secure communication, plays a vital role in protecting sensitive information from unauthorized access. The course delves into classical cryptography, examining substitution and transposition techniques used to encrypt and decrypt messages. You learn about monoalphabetic, polyalphabetic, and homophonic substitution methods, as well as various transposition techniques. This foundation in classical cryptography serves as a springboard for understanding modern cryptographic concepts.

Modern cryptography is explored through symmetric and asymmetric encryption, including block ciphers, stream ciphers, and public-key cryptography. You gain insight into encryption algorithms, such as AES and RSA, and learn about key management, digital signatures, and cryptographic protocols.

The course emphasizes the importance of cryptography in modern security, highlighting its applications in secure communication, data protection, and digital commerce. You have been able to examine real-world scenarios, analyzing the role of cryptography in protecting sensitive information and ensuring the integrity and authenticity of data. Throughout the course, you develop critical thinking skills, evaluating the strengths and weaknesses of various cryptographic techniques and algorithms. You learn to assess the security of cryptographic systems and identify potential vulnerabilities.

By mastering cryptography's fundamental principles and techniques, students gain a deep understanding of secure communication and data protection. This knowledge enables them to design and implement secure systems, protecting sensitive information from unauthorized access.

The course provides a solid foundation for advanced studies in cryptography, preparing you for careers in cybersecurity, information assurance, and related fields. As technology advances and security threats evolve, the importance of cryptography in protecting sensitive information will continue to grow.

Upon completing this course, you will have a comprehensive understanding of cryptography's role in modern security, enabling them to contribute to the development of secure communication systems and protect sensitive information in an increasingly interconnected world.

5.0 Self-Assessment Exercise(s)

1. Analyze the design principles of modern block ciphers, including substitution-permutation networks. Explain how these principles contribute to the security of modern block ciphers, using AES as an example.
2. Evaluate the security strengths and weaknesses of different block cipher modes of operation.
3. Choose an appropriate mode for a specific application, such as secure data storage or network communication, and justify your choice.

Answers

Exercise 1: Design Principles of Modern Block Ciphers

Modern block ciphers, such as AES, employ substitution-permutation networks (SPNs) to provide confidentiality and integrity. Key design principles include:

- Substitution boxes (S-boxes) for non-linear transformations
- Permutation layers for diffusion
- Round keys for varied encryption
- Number of rounds for increased security

These principles contribute to security by:

- Preventing differential and linear cryptanalysis
- Ensuring high entropy and randomness
- Making brute-force attacks computationally infeasible

Exercise 2: Security Strengths and Weaknesses of Block Cipher Modes

Common modes include Electronic Codebook (ECB), Cipher Block Chaining (CBC), Cipher Feedback (CFB), Output Feedback (OFB) and Counter (CTR)

Security strengths and weaknesses:

- ECB: simple, but vulnerable to block replay attacks
- CBC: secure, but requires padding and IV management
- CFB and OFB: secure, but sensitive to error propagation
- CTR: secure, efficient, and parallelizable

Exercise 3: Choosing an Appropriate Mode

For secure data storage, choose CBC mode, because:

- It provides confidentiality and integrity
- It supports random access and parallel processing
- It is well-established and widely implemented

For network communication, choose CTR mode:

- It is efficient and parallelizable
- It is resistant to error propagation
- It supports high-speed encryption and decryption

Justification:

CBC's security features and widespread adoption make it suitable for data storage while CTR's efficiency and resistance to error propagation make it ideal for network communication. By understanding modern block cipher design principles and modes of operation, individuals can select appropriate cryptographic solutions for specific applications, ensuring the confidentiality, integrity, and authenticity of sensitive information.

6.0 Conclusion

Modern block ciphers are a fundamental component of modern cryptography, providing confidentiality, integrity, and authenticity of data. The Advanced Encryption Standard (AES) is a widely adopted and trusted block cipher, offering superior security and performance. The principles of confusion and diffusion, substitution-permutation networks, and modes of operation ensure the security and integrity of data. Through analysis, evaluation, and implementation, students have gained a deep understanding of modern block ciphers and their applications. They have developed the skills to analyze and evaluate the security and performance of various block ciphers, recommending appropriate ciphers for specific use cases. With a solid foundation in modern block ciphers, students are prepared for advanced studies in cryptography and cybersecurity, enabling them to contribute to the development of secure and reliable data storage and communication systems.

7.0 Summary

Modern block ciphers are a crucial component of cryptography, ensuring data confidentiality, integrity, and authenticity. The Advanced Encryption Standard (AES) is a widely adopted and trusted block cipher, offering superior security and performance. Students have gained a deep understanding of modern block ciphers through analysis, evaluation, and implementation, developing skills to assess their security and performance. They can recommend appropriate ciphers for specific use cases, preparing them for advanced studies in cryptography and cybersecurity.

Modern block ciphers operate on principles of confusion and diffusion, using substitution-permutation networks and modes of operation to ensure security. AES, a substitution-permutation network, is a widely used and trusted algorithm. Students have learned to evaluate block cipher modes, such as ECB, CBC, and GCM, and implement simple block ciphers using programming languages and cryptographic libraries.

Through this module, students have developed a solid foundation in modern block ciphers, enabling them to contribute to the development of secure data storage and communication systems. They can analyze and evaluate the security and performance of various block ciphers, recommending appropriate ciphers for specific applications. This knowledge is essential for

advanced studies in cryptography and cybersecurity, preparing students for careers in secure system development and deployment.

8.0 Tutor Marked Assignment

- Write a short note explaining the concepts of substitution and permutation, how they are applied in AES, and their importance in ensuring the security of modern block ciphers.
- Explain the importance of key management in modern block ciphers
- Compare and contrast two modern block ciphers (such as AES and DES)
- Discuss the importance of key management in modern block ciphers, including key generation, distribution, storage, and revocation. Explain the consequences of poor key management and recommend best practices for secure key management.

9.0 Further Reading

Barker, E. B., & Roginsky, A. L. (2020). Recommendation for the Advanced Encryption Standard (AES). National Institute of Standards and Technology (NIST), 800-38A. <https://nvlpubs.nist.gov/nistpubs/legacy/sp/nistspecialpublication800-38a.pdf>

Katz, J., & Lindell, Y. (2020). Introduction to modern cryptography (3rd ed.). CRC Press. <https://www.taylorfrancis.com/books/mono/10.1201/9781351133036/introduction-modern-cryptography-jonathan-katz-yehuda-lindell>

Paar, C., & Pelzl, J. (2021). Understanding cryptography: A textbook for students and practitioners(2nded.)Springer.https://www.academia.edu/18966194/Understanding_Cryptography_A_Textbook_for_Students_and_Practitioners

UNIT 4: Stream Ciphers (Concept, Advantages, and Disadvantages)

Contents

1.0 Introduction

2.0 Intended Learning Outcomes

3.0 Concept and Techniques of Stream Ciphers

3.1 Advantages of Stream Ciphers

3.2 Disadvantages of Stream Cyphers

4.0 Discussion

5.0 Self-Assessment Exercise(s)

6.0 Conclusion

7.0 Summary

8.0 Tutor Marked Assignment

9.0 Further Readings

1.0 Introduction

In this unit, we will explore the fundamental concepts and techniques of stream ciphers, a crucial component of modern cryptography. Stream ciphers are widely used in various applications, including network communication protocols, online transactions, and mobile devices, due to their high speed and efficiency. We will delve into the principles of stream cipher operation, keystream generation, and encryption techniques. Students will gain a comprehensive understanding of the advantages, limitations, and applications of stream ciphers, enabling them to analyze and evaluate their use in various cryptographic contexts.

2.0 Intended Learning Outcomes

1. Explain the fundamental principles of stream ciphers, including the generation of pseudorandom key streams and their combination with plaintext data.

2. Describe the advantages and limitations of stream ciphers, including their high speed and efficiency, and potential vulnerabilities.

3. Analyze and evaluate the applications and uses of stream ciphers in modern cryptography, including network communication protocols and online transactions.

3.0 Concepts and Techniques of Stream Cyphers

Stream ciphers are a type of symmetric-key encryption algorithm that encrypts data in a continuous stream, bit by bit or byte by byte. The core concept of stream ciphers is the generation of a pseudorandom keystream, which is combined with the plaintext data to produce the ciphertext. This keystream is generated from a key and an algorithm, designed to produce a sequence of bits that appears random and unpredictable.

The key stream generation is a crucial aspect of stream ciphers, as it determines the security of the encryption. The algorithm used to generate the keystream must be designed to produce a sequence that is statistically random and unpredictable, making it difficult for an attacker to decipher the encrypted data. Various techniques are employed to achieve this, including the use of linear and non-linear feedback shift registers, clock-controlled generators, and filter generators.

It is important to note that, stream ciphers operate in real-time, making them highly efficient and suitable for applications that require high-speed encryption, such as network communication protocols and online transactions. They are also commonly used in mobile devices and other applications where speed and efficiency are crucial. The encryption process is typically done using a simple XOR operation between the plaintext data and the keystream, making it fast and efficient. However, stream ciphers require careful management of the keystream and the keys used. If the keystream is predictable or the keys are compromised, the encryption can be vulnerable to attacks.

Therefore, it is essential to ensure that the keystream is generated securely and that the keys are managed properly. Stream ciphers are a powerful tool for encryption, offering high speed and efficiency. However, their security relies heavily on the quality of the keystream and the management of the keys used. By understanding the concepts and techniques of stream ciphers, developers and security professionals can harness their potential to provide robust encryption for various applications.

Basic Concept of Stream Cyphers

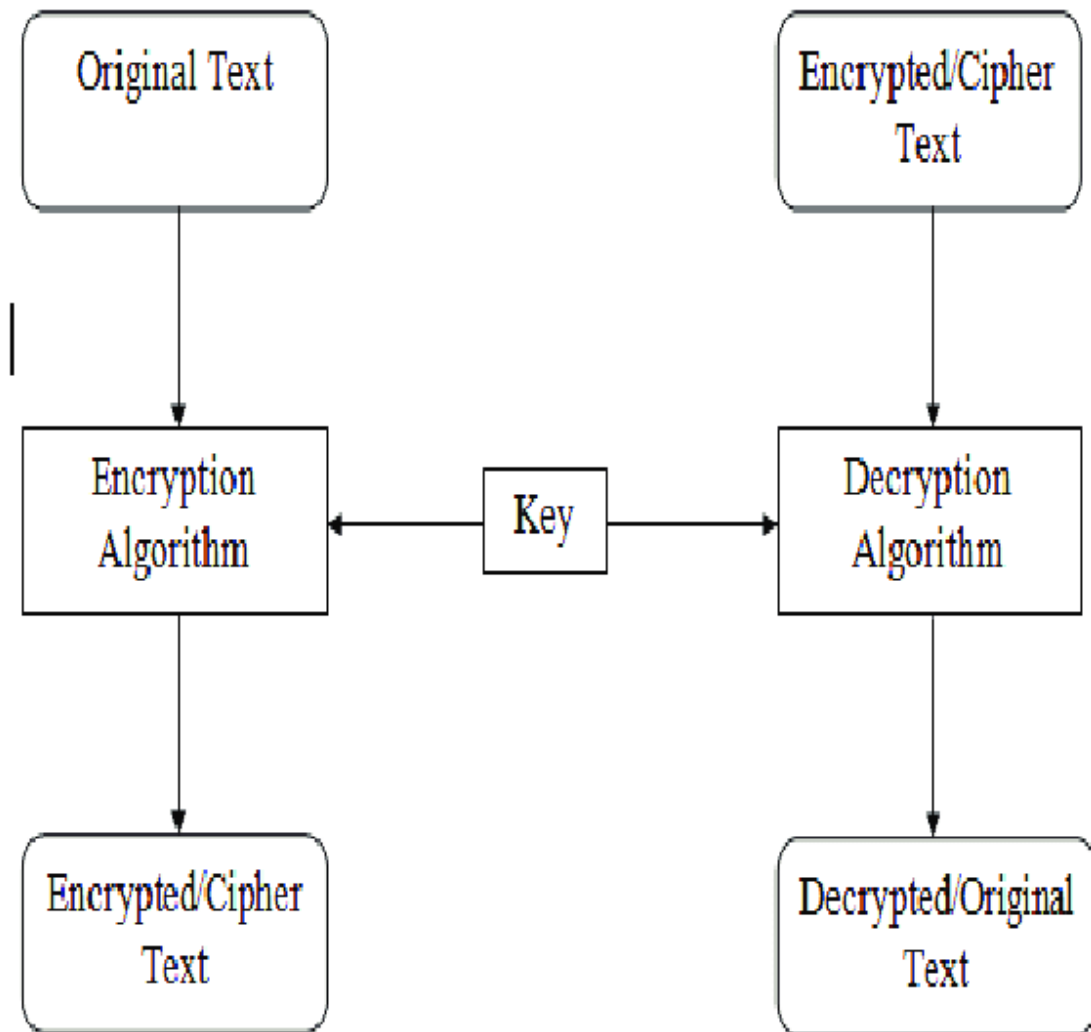

From Danti, A., & Nayak, R. (2013)

3.1 Advantages of Stream Cypher

Stream ciphers have several advantages that make them a popular choice for many applications:

- i. **High speed:** Stream ciphers are extremely fast and efficient, making them suitable for real-time encryption and decryption.
- ii. **Low overhead:** Stream ciphers require minimal computational resources and memory, making them ideal for resource-constrained devices.
- iii. **Simple implementation:** Stream ciphers are relatively easy to implement and integrate into existing systems.
- iv. **High security:** Stream ciphers can provide high security if designed and implemented properly, making them suitable for sensitive data.
- v. **Flexibility:** Stream ciphers can be used for both encryption and decryption, and can be easily adapted for various applications.
- vi. **Low power consumption:** Stream ciphers are suitable for battery-powered devices, as they require minimal power to operate.
- vii. **Resistance to side-channel attacks:** Stream ciphers are resistant to side-channel attacks, such as timing and power analysis attacks.

3.2 Disadvantages of Stream Cyphers

Stream ciphers also have some disadvantages:

- i. Security relies on keystream quality: If the keystream is predictable or not truly random, the encryption can be vulnerable to attacks.
- ii. Key management: Stream ciphers require careful key management, as the same key should not be used twice.
- iii. Synchronization issues: If the encryption and decryption processes lose synchronization, the data can become garbled or lost.
- iv. Error propagation: A single error in the transmission or encryption process can propagate and affect the entire ciphertext.
- v. Limited randomness: Some stream ciphers may not produce truly random keystreams, making them vulnerable to attacks.
- vi. Vulnerability to certain attacks: Stream ciphers are vulnerable to attacks such as cipher exhaustion attacks, and attacks that exploit weaknesses in the keystream generation.
- vii. Limited flexibility: Stream ciphers are designed for encryption and decryption, and are not suitable for other cryptographic tasks like digital signatures or authentication.

It is imperative to carefully consider these disadvantages when designing and implementing stream cipher systems, and to take appropriate measures to mitigate them.

4.0 Discussion

This course unit delves into the fundamental concepts and techniques of stream ciphers, a crucial component of modern cryptography. Stream ciphers are symmetric-key encryption algorithms that encrypt data in a continuous stream, bit by bit or byte by byte, making them highly efficient and suitable for real-time applications.

The unit explores the principles of stream cipher operation, keystream generation, and encryption techniques. You learn about the advantages of stream ciphers, including high speed, low overhead, simple implementation, and resistance to side-channel attacks. However, the unit also discusses the limitations and potential vulnerabilities of stream ciphers, such as security reliance on keystream quality, key management issues, synchronization problems, error propagation, and vulnerability to certain attacks.

Through this unit, you gain a comprehensive understanding of stream ciphers and their applications in modern cryptography, including network communication protocols, online transactions, and mobile devices. You also develop critical thinking skills to analyze and evaluate the use of stream ciphers in various cryptographic contexts.

The unit further emphasizes the importance of careful key management, keystream generation, and synchronization to ensure the security and effectiveness of stream cipher systems. By understanding the concepts and techniques of stream ciphers, developers and security professionals can harness their potential to provide robust encryption for various applications.

Ultimately, you will be able to explain the fundamental principles of stream ciphers, describe their advantages and limitations, and analyze and evaluate their applications in modern cryptography.

5.0 Self-Assessment Exercise(s)

- i. Explain the fundamental principles of stream ciphers, including the generation of pseudorandom keystreams and their combination with plaintext data.

- ii. Describe the advantages and limitations of stream ciphers, including their high speed and efficiency, and potential vulnerabilities. Provide an example of a scenario where a stream cipher would be an appropriate choice, and another scenario where it would not be suitable.
- iii. Analyze and evaluate the applications and uses of stream ciphers in modern cryptography, including network communication protocols and online transactions.

Answers

Exercise 1: Fundamental Principles of Stream Ciphers

Stream ciphers operate on the principle of generating a pseudorandom keystream, which is combined with plaintext data to produce ciphertext. The keystream is generated from a key and an algorithm, designed to produce a sequence of bits that appears random and unpredictable.

Key components:

- Keystream generation: Using linear or non-linear feedback shift registers, clock-controlled generators, or filter generators.
- Combination with plaintext: XOR operation between keystream and plaintext.
- Synchronization: Ensuring encryption and decryption processes remain synchronized.

Exercise 2: Advantages and Limitations of Stream Ciphers

Advantages:

- High speed and efficiency
- Low overhead and computational resources
- Simple implementation
- Resistance to side-channel attacks

Disadvantages:

- Security relies on keystream quality

- Key management issues
- Synchronization problems
- Error propagation
- Vulnerability to certain attacks (e.g., cipher exhaustion)

Scenario 1: Stream Cipher Suitable

Online banking transactions require high-speed encryption to secure sensitive data. Stream ciphers, such as RC4, are suitable due to their efficiency and low latency.

Scenario 2: Stream Cipher Not Suitable

Digital signatures for software distribution require non-repudiation and authenticity. Stream ciphers are not suitable, as they do not provide digital signature functionality. Instead, asymmetric cryptography (e.g., RSA) is used.

Exercise 3: Applications and Uses of Stream Ciphers

Stream ciphers are widely used in:

- Network communication protocols (e.g., SSL/TLS, Wi-Fi)
- Online transactions (e.g., banking, e-commerce)
- Mobile devices (e.g., secure messaging apps)
- Real-time encryption applications (e.g., video conferencing)

6.0 Conclusion

Stream ciphers are a type of symmetric-key encryption algorithm that offers high speed and efficiency, making them suitable for real-time encryption and decryption. They operate by generating a pseudorandom keystream that is combined with plaintext data to produce ciphertext. While they offer several advantages, including low overhead, simple implementation, and high security, they also have limitations and potential vulnerabilities, such as reliance on keystream quality, key management issues, and susceptibility to certain attacks.

To harness the potential of stream ciphers, it is essential to carefully consider their advantages and limitations, and take appropriate measures to mitigate their vulnerabilities. By understanding the

concepts and techniques of stream ciphers, developers and security professionals can design and implement secure encryption systems for various applications

7.0 Summary

Stream ciphers are a type of encryption algorithm that offers high speed and efficiency, but also come with potential vulnerabilities. They are suitable for real-time encryption and decryption, but require careful consideration of their limitations and potential vulnerabilities to ensure secure implementation. Key points include:

- High speed and efficiency
- Pseudorandom keystream generation
- Vulnerability to attacks if keystream is predictable
- Key management issues
- Limited flexibility

By understanding the advantages and limitations of stream ciphers, developers and security professionals can design and implement secure encryption systems for various applications.

8.0 Tutor Marked Assignment

- Explain the fundamental principles of stream ciphers, including the generation of pseudorandom keystreams and their combination with plaintext data
- Compare and contrast the advantages and limitations of stream ciphers, including their high speed and efficiency, and potential vulnerabilities
- Design and describe a stream cipher algorithm, including the keystream generation process and the encryption/decryption process.

9.0 Further Readings

Abead, S. A., & Ali, N. H. M. (2024). Lightweight Block and Stream Cipher Algorithm: A Review. *Journal of Applied Engineering and Technological Science (JAETS)*, 5(2), 860-874. <https://journal.yrpiiku.com/index.php/jaets/article/download/3966/2911/27929>

Hikmat Ismael, Y. (2023). BLOCK CIPHER PERFORMANCE AND RISK ANALYSIS. *AL-Rafidain Journal of Computer Sciences and Mathematics*, 17(1), 23-33.
<https://www.iasj.net/iasj/issue/14414>

Memon, T. (2013). Stream Cipher Introduction & Algorithm Implementation: Secret Keyography (SKC) in Network Security.
https://www.researchgate.net/publication/325326305_Design_and_Implementation_of_Secure_Stream_Cipher_Algorithm

Danti, A., & Nayak, R. (2013). Data Encryption by Excluding Repetitive Character in Cipher Text. *International Journal Of Innovationsin Engineering And Technology (IJJET)*, 2(4), 270-276.
https://www.researchgate.net/publication/315516219_Data_Encryption_by_Excluding_Repetitive_Character_in_Cipher_Text

Module 3: Clarifications of Complex Cryptographic Concepts

Introduction

Module 3 expands on the foundational knowledge introduced in Module 1, clarifying complex concepts and providing a deeper understanding of various cryptography types crucial for secure communication and online transactions. This module delves into Asymmetric Cryptography, Key Management, Digital Signatures, and Message Integrity, further solidifying your understanding of these essential topics.

Unit 1: Asymmetric Cryptography

Unit 2: Applications of Asymmetric Cryptography (Diffie-Hellman key exchange, One-Way Functions, RSA, El Gamal cryptosystem)

Unit 3: Asymmetric Key Management and Security (Importance, Standards, Public Key Infrastructure, Certificates, Certification Authority)

Unit 4: Digital Signature and Message Integrity (Methods, Hash functions, Digital Signature Systems)

UNIT 1: Asymmetric Cryptography

Contents

1.0 Introduction

2.0 Intended Learning Outcomes

3.0 Basic Concept of Asymmetric Cryptography

3.1 Asymmetric Encryption Algorithms

3.2 Advantages and Disadvantages of Asymmetric Encryption Algorithm

4.0 Discussion

5.0 Self-Assessment Exercise(s)

6.0 Conclusion

7.0 Summary

8.0 Tutor Marked Assignment

9.0 Further Readings

1.0 Introduction

This unit explores the principles and techniques of asymmetric cryptography, which uses a pair of keys - a public key for encryption and a private key for decryption. You will learn how asymmetric cryptography provides secure communication, digital signatures, and authentication, and understand the algorithms and protocols that underlie secure online transactions, digital signatures, and message integrity. By the end of this course unit, students will have a deep understanding of the concepts, benefits, and applications of asymmetric cryptography.

2.0 Intended Learning Outcomes

1. Explain the fundamental principles of asymmetric cryptography, including public-key cryptography and the concept of key pairs
2. Describe the advantages and limitations of asymmetric cryptography compared to symmetric cryptograph
3. Identify and explain the different types of asymmetric cryptography algorithms, such as RSA and elliptic curve cryptography.

3.0 Basic Concept of Asymmetric Cryptography

Asymmetric cryptography, also known as public-key cryptography, is a fundamental concept in modern cryptography. It uses a pair of keys - a public key for encryption and a private key for decryption. This approach revolutionized cryptography by enabling secure communication between parties without sharing a secret key. In asymmetric cryptography, the public key is freely distributed, while the private key is kept confidential. When data is encrypted with the public key, only the corresponding private key can decrypt it. This ensures that even if an unauthorized party intercepts the encrypted data, they cannot access the contents without the private key.

The mathematical basis of asymmetric cryptography relies on complex algorithms, such as factoring large numbers (RSA) or elliptic curve calculations. These algorithms make it computationally infeasible to derive the private key from the public key, ensuring the security of the system. Asymmetric cryptography enables various cryptographic techniques, including:

- Secure communication: Encrypted data can be shared publicly, without revealing the contents.
- Digital signatures: A message signed with a private key can be verified using the corresponding public key.
- Key exchange: Public keys can be used to establish a shared secret key between parties.

Asymmetric cryptography has transformed the way we secure online transactions, communication, and data. Its applications include secure web browsing (HTTPS), email encryption, digital signatures, and cryptocurrencies like Bitcoin. The fundamental concept of asymmetric cryptography has enabled trustable and secure interactions over the internet.

An illustration of Asymmetric Cryptography

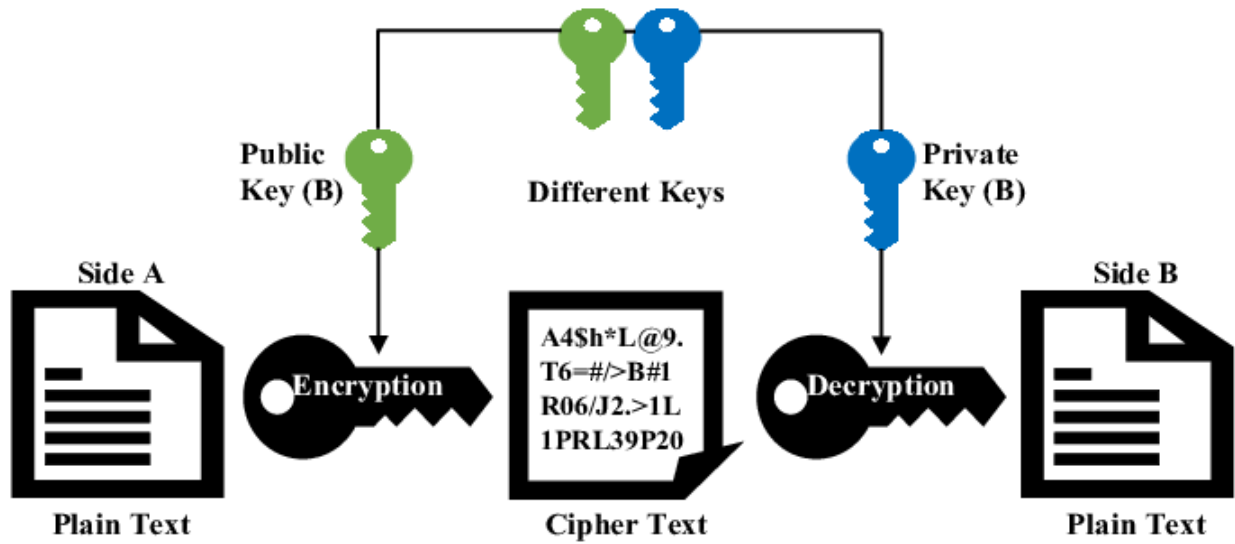

Hussein, H. I., Mstafa, R. J., Mohammed, A. O., & Younis, Y. M. (2022, March).

3.1 Asymmetric Encryption Algorithm (AEA)

Asymmetric Encryption Algorithm (AEA), also known as public-key cryptography, is a cryptographic technique that uses a pair of keys for encryption and decryption. This technique ensures secure data transmission and reception. Key features of Asymmetric Encryption Algorithm include:

- Unique key pair: A public key for encryption and a private key for decryption.
- Mathematical relationship: Keys are mathematically related, making it impossible to derive the private key from the public key.
- Encryption: Data is encrypted using the public key, making it unreadable to unauthorized users.
- Decryption: Data is decrypted using the private key, ensuring only intended recipients can access the data

Illustration of asymmetric encryption algorithm workflow.

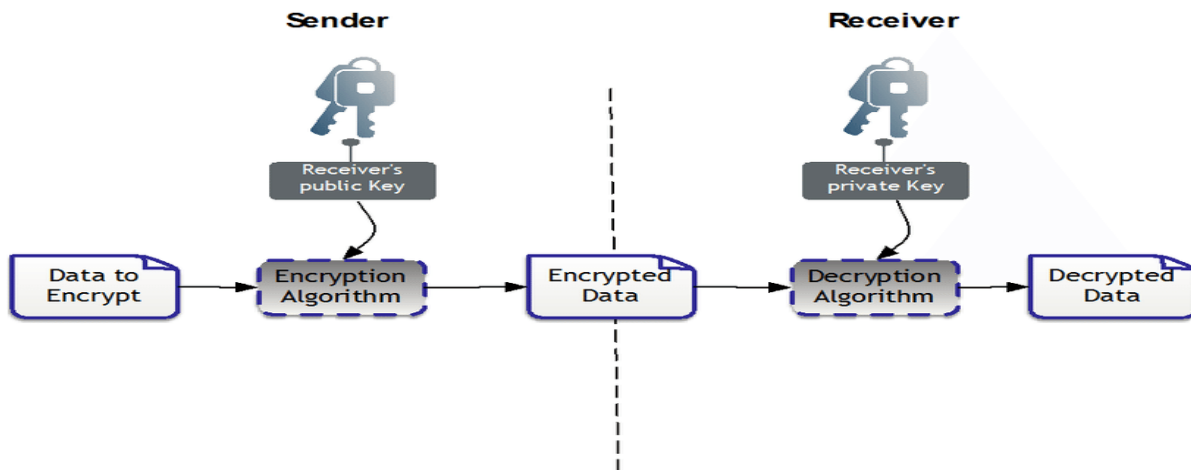

Silva, B. M., Rodrigues, J. J., Canelo, F., Lopes, I. M., & Lloret, J. (2019)

3.2 Advantages and Disadvantages of Asymmetric Encryption Algorithm

Despite its numerous advantages, Asymmetric Encryption Algorithm (AEA) is not without its limitations. In this discussion, we will delve into both the benefits and drawbacks of AEA, providing a comprehensive understanding of its applications and the contexts in which its use is most suitable. By examining both sides, we can gain a deeper appreciation for the role AEA plays in the realm of cryptography and make informed decisions about its implementation. Some of its advantages are highlighted below

- Secure key exchange: AEA enables secure key exchange between parties without physically meeting.
- Digital signatures: AEA enables creation of digital signatures, authenticating the sender and ensuring data integrity.
- High security: AEA provides high security due to the mathematical complexity of deriving the private key from the public key.

Examples of AEA include RSA (Rivest-Shamir-Adleman), elliptic curve cryptography, and PGP (Pretty Good Privacy). AEA is widely used in secure online transactions, email

encryption, and digital signatures, ensuring the confidentiality, authenticity, and integrity of data.

Asymmetric Encryption Algorithm (AEA) has several disadvantages:

- **Key management:** Managing public and private keys is complex, especially in large-scale implementations.
- **Computational overhead:** AEA is slower than symmetric encryption due to the complex mathematical operations involved.
- **Key size:** Larger key sizes are required for adequate security, increasing computational overhead.
- **Certificate management:** Public keys must be authenticated via digital certificates, adding administrative burden.
- **Private key security:** Losing or compromising private keys can lead to data loss or unauthorized access.
- **Quantum computing vulnerability:** AEA is vulnerable to quantum computer attacks, potentially compromising security in the future.
- **Limited scalability:** AEA can become impractical for very large datasets or high-speed applications due to computational overhead.
- **Interoperability issues:** Different AEA implementations may not be compatible, hindering interoperability between systems.

4.0 Discussion

This course unit delves into the principles and techniques of asymmetric cryptography, a fundamental concept in modern cryptography. Asymmetric cryptography utilizes a pair of keys - a public key for encryption and a private key for decryption - enabling secure communication, digital signatures, and authentication. The course explores the basic concept of asymmetric cryptography, including public-key cryptography and the concept of key pairs. It discusses the advantages and limitations of asymmetric cryptography compared to symmetric cryptography and identifies various types of asymmetric cryptography algorithms, such as RSA and elliptic curve cryptography.

Asymmetric cryptography has revolutionized secure online transactions, digital signatures, and message integrity. Its applications include secure web browsing (HTTPS), email encryption, digital signatures, and cryptocurrencies like Bitcoin. The mathematical basis of asymmetric cryptography relies on complex algorithms, making it computationally infeasible to derive the private key from the public key.

The course further highlights the advantages of asymmetric cryptography, including secure key exchange, digital signatures, and high security. However, it also discusses the limitations, such as key management complexity, computational overhead, key size requirements, certificate management, private key security, quantum computing vulnerability, limited scalability, and interoperability issues.

Through this course, you gain a comprehensive understanding of asymmetric cryptography's concepts, benefits, and applications. You also develop critical thinking skills to analyze and evaluate the use of asymmetric cryptography in various contexts.

Asymmetric cryptography plays a vital role in securing online transactions and communication. Its applications continue to grow, and understanding its principles and techniques is essential for developing secure systems. This course provides a solid foundation for advanced studies in cryptography and prepares learners for careers in cybersecurity, information assurance, and related fields. The importance of asymmetric cryptography will continue to grow as technology advances and security threats evolve. Its role in enabling trustable and secure interactions over the internet has transformed the way we conduct online transactions, communicate, and protect sensitive information.

5.0 Self-Assessment Exercise(s)

- i. Explain the fundamental principles of asymmetric cryptography, including public-key cryptography.
- ii. Compare and contrast asymmetric cryptography with symmetric cryptography.
- iii. Describe the advantages and limitations of Asymmetric Encryption Algorithm.

Answers

Exercise 1: Fundamental Principles of Asymmetric Cryptography

Asymmetric cryptography, also known as public-key cryptography, relies on the following fundamental principles:

- **Key pair:** A pair of keys, consisting of a public key and a private key.
- **Public key encryption:** Data encrypted with the public key can only be decrypted with the corresponding private key.
- **Mathematical relationship:** The public and private keys are mathematically related, making it computationally infeasible to derive the private key from the public key.
- **Key distribution:** Public keys are freely distributed, while private keys remain confidential.

Exercise 2: Comparison of Asymmetric and Symmetric Cryptography

Similarities:

- Both provide confidentiality and integrity.
- Both use encryption algorithms.

Differences:

- **Key management:** Asymmetric cryptography uses key pairs, while symmetric cryptography uses a shared secret key.
- **Encryption process:** Asymmetric cryptography encrypts data with the public key and decrypts with the private key, whereas symmetric cryptography uses the same key for encryption and decryption.
- **Scalability:** Symmetric cryptography is faster and more scalable.
- **Security:** Asymmetric cryptography provides better security due to the mathematical complexity of deriving the private key.

Exercise 3: Advantages and Limitations of Asymmetric Encryption Algorithm

Advantages:

- **Secure key exchange:** Enables secure key exchange between parties.
- **Digital signatures:** Authenticates sender and ensures data integrity.
- **High security:** Provides high security due to mathematical complexity.

- Scalability: Suitable for large-scale applications.

Limitations:

- Computational overhead: Slower than symmetric encryption.
- Key management complexity: Managing public and private keys.
- Key size requirements: Larger key sizes required.
- Quantum computing vulnerability: Potential security risk.
- Interoperability issues: Different implementations may not be compatible.

6.0 Conclusion

In conclusion, this unit has provided a comprehensive understanding of asymmetric cryptography, a fundamental concept in modern cryptography. We have explored the principles of public-key cryptography and basis of asymmetric encryption algorithms like RSA and elliptic curve cryptography. The advantages of asymmetric cryptography, including secure key exchange, digital signatures, and high security, make it a crucial tool for secure online transactions, email encryption, and digital signatures. However, its limitations, such as key management complexities and computational overhead, must be considered when implementing asymmetric cryptography. By understanding the concepts, benefits, and applications of asymmetric cryptography, we can harness its potential to ensure confidentiality, authenticity, and integrity of data in various cryptographic techniques. As technology advances, the importance of asymmetric cryptography will only continue to grow, making it essential to stay informed about its developments and applications.

7.0 Summary

In summary, this unit covered the basics of asymmetric cryptography, including public-key cryptography and Asymmetric Encryption Algorithm (AEA), its advantages such as secure key exchange, digital signatures, and high security, as well as its limitations like key management and computational overhead. The unit also briefly explored algorithms like RSA and elliptic curve cryptography, and their applications in secure online transactions, email encryption, and digital signatures. Asymmetric cryptography is a powerful tool for secure data transmission and reception, with both benefits and challenges.

8.0 Tutor Marked Assignment

- Explain the concept of asymmetric cryptography and its key features. Describe a scenario where asymmetric cryptography is used to secure online transactions.
- Compare and contrast symmetric and asymmetric cryptography. Discuss the advantages and limitations of each and provide examples of their applications.

8.0 Further Readings

Paar, C., Pelzl, J., & Güneysu, T. (2024). Introduction to public-key cryptography. In *Understanding Cryptography: From Established Symmetric and Asymmetric Ciphers to Post-Quantum Algorithms* (pp. 177-203). Berlin, Heidelberg: Springer Berlin Heidelberg. <https://gnavavelrec.wordpress.com/wp-content/uploads/2019/06/2.understanding-cryptography-by-christof-paar-.pdf>

Hussein, H. I., Mstafa, R. J., Mohammed, A. O., & Younis, Y. M. (2022, March). An enhanced ElGamal cryptosystem for image encryption and decryption. In *2022 International Conference on Computer Science and Software Engineering (CSASE)* (pp. 337-342). IEEE. https://www.researchgate.net/publication/360196362_An_Enhanced_ElGamal_Cryptosystem_for_Image_Encryption_and_Decryption

Silva, B. M., Rodrigues, J. J., Canelo, F., Lopes, I. M., & Lloret, J. (2019). Towards a cooperative security system for mobile-health applications. *Electronic Commerce Research*, 19, 629-654.

https://www.researchgate.net/publication/287902463_Towards_a_cooperative_security_system_for_mobile-health_applications

UNIT 2: Applications of Asymmetric Cryptography

Contents

1.0 Introduction

2.0 Intended Learning Outcomes

3.0 Applications of Asymmetric Cryptography

3.1 Diffie-Hellman key exchange

3.2 One-Way Functions

3.3 RSA

3.4 El Gamal cryptosystem

4.0 Discussion

5.0 Self-Assessment Exercise(s)

6.0 Conclusion

7.0 Summary

8.0 Tutor Marked Assignment

9.0 Further Readings

1.0 Introduction

This unit delves into the applications of asymmetric cryptography, exploring its role in secure online transactions, digital signatures, email encryption, and more. Students will gain a deep of techniques that underlie modern cryptographic systems, preparing them to tackle real-world challenges in cybersecurity, data privacy, and digital trust. By the end of this unit, students will be able to understand how asymmetric cryptography are used in designing and implementing secure communication systems, ensuring the protection of sensitive information in an increasingly connected world.

2.0 Intended Learning Outcomes

1. Explain the fundamental principles of asymmetric cryptography, including public-key cryptography, key pairs, and encryption/decryption processes

2. Analyze and compare different asymmetric cryptographic algorithms, such as RSA and elliptic curve cryptography, in terms of their security, performance, and applications.
3. Design and implement secure communication systems using asymmetric cryptography.

3.0 Applications of Asymmetric Cryptography

Asymmetric cryptography, a transformative technology, has far-reaching implications in today's digital landscape. From e-commerce transactions to digital signatures, and from secure messaging to blockchain technology, asymmetric cryptography plays a vital role in protecting data and maintaining trust in various industries. As mentioned earlier, we will explore the real-world applications and use cases of asymmetric cryptography, highlighting its significance in shaping the future of secure digital interactions.

3.1 Diffie-Hellman Key Exchange

The Diffie-Hellman key exchange is a groundbreaking application of asymmetric cryptography, enabling secure key establishment between parties over an insecure communication channel. Developed in 1976 by Whitfield Diffie and Martin Hellman, this method revolutionized secure communication by allowing parties to exchange cryptographic keys without actually exchanging the keys themselves.

In the Diffie-Hellman key exchange, each party generates a public and private key pair. They then exchange their public keys, which are used to compute a shared secret key. This shared key is never transmitted, ensuring its secrecy. Both parties can now use this shared key for symmetric encryption and decryption, providing secure communication. It is a fundamental component of various secure protocols, including Secure Sockets Layer (SSL), Transport Layer Security (TLS), and Internet Protocol Security (IPSec). Its significance extends beyond secure web browsing, as it also enables secure communication in virtual private networks (VPNs), email encryption, and other applications requiring secure key exchange.

The Diffie-Hellman key exchange has had a profound impact on modern cryptography, demonstrating the power of asymmetric cryptography in facilitating secure communication over public channels. Its influence continues to be felt, shaping the development of secure communication protocols and applications.

Illustration of Diffie-Hellman key exchange Structure

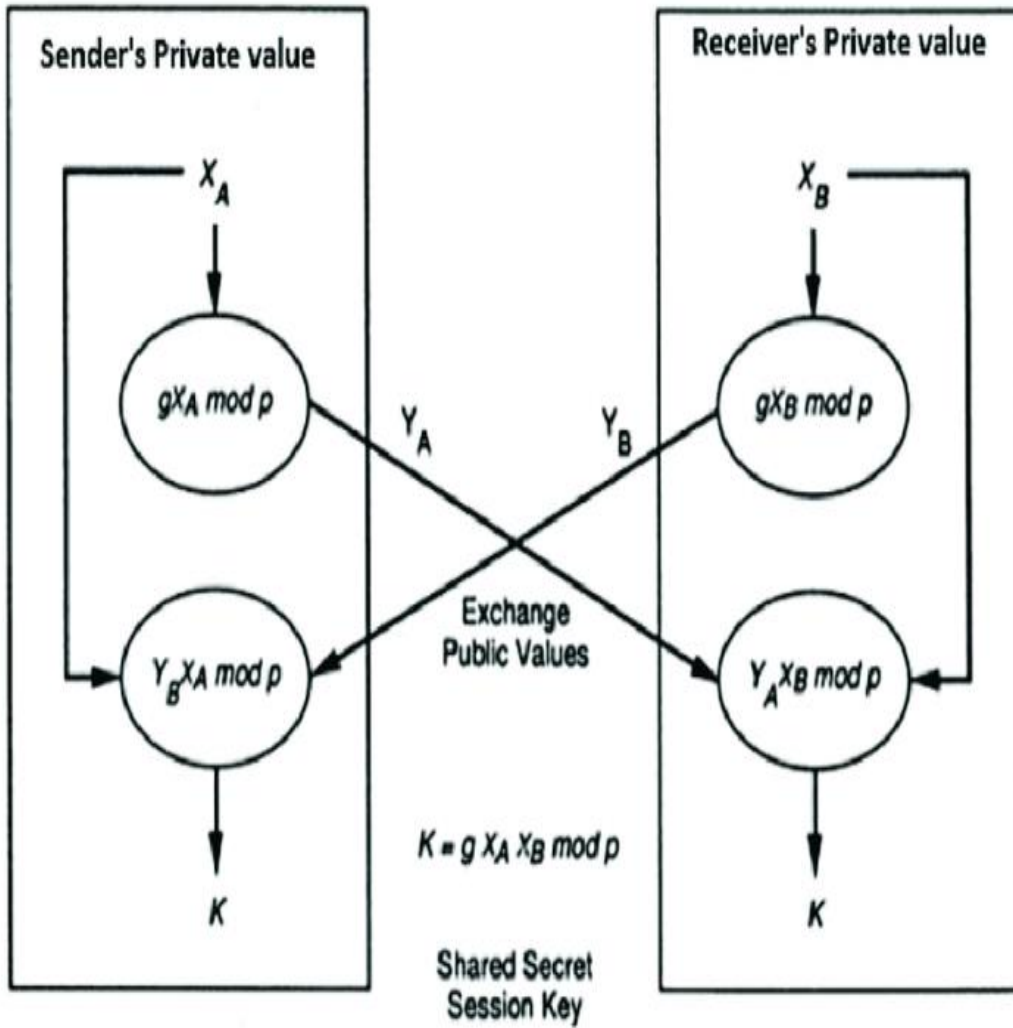

Silva, B. M., Rodrigues, J. J., Canelo, F., Lopes, I. M., & Lloret, J. (2019).

3.2 One-Way Functions (OWFs)

One-Way Functions (OWFs) are a fundamental application of asymmetric cryptography, playing a crucial role in ensuring the security of various cryptographic protocols. A One-Way Function is

a mathematical function that is easy to compute in one direction but extremely difficult to invert, making it a "one-way" street.

In asymmetric cryptography, OWFs are used to enable secure key establishment, digital signatures, and encryption schemes. The most common OWF used is the modular exponentiation function, which is the foundation of popular cryptographic algorithms like RSA and Diffie-Hellman.

The importance of OWFs lies in their ability to ensure the secrecy of private keys and the authenticity of messages. In digital signatures, OWFs are used to sign messages, making it impossible for an attacker to forge a signature. In encryption schemes, OWFs are used to encrypt data, ensuring that only the intended recipient can decrypt it. The security of many cryptographic protocols relies on the existence of OWFs, making them a fundamental building block of modern cryptography. The study and development of OWFs continue to be an active area of research, driving innovation in cryptographic techniques and applications.

Structure of One-Way Function Tree

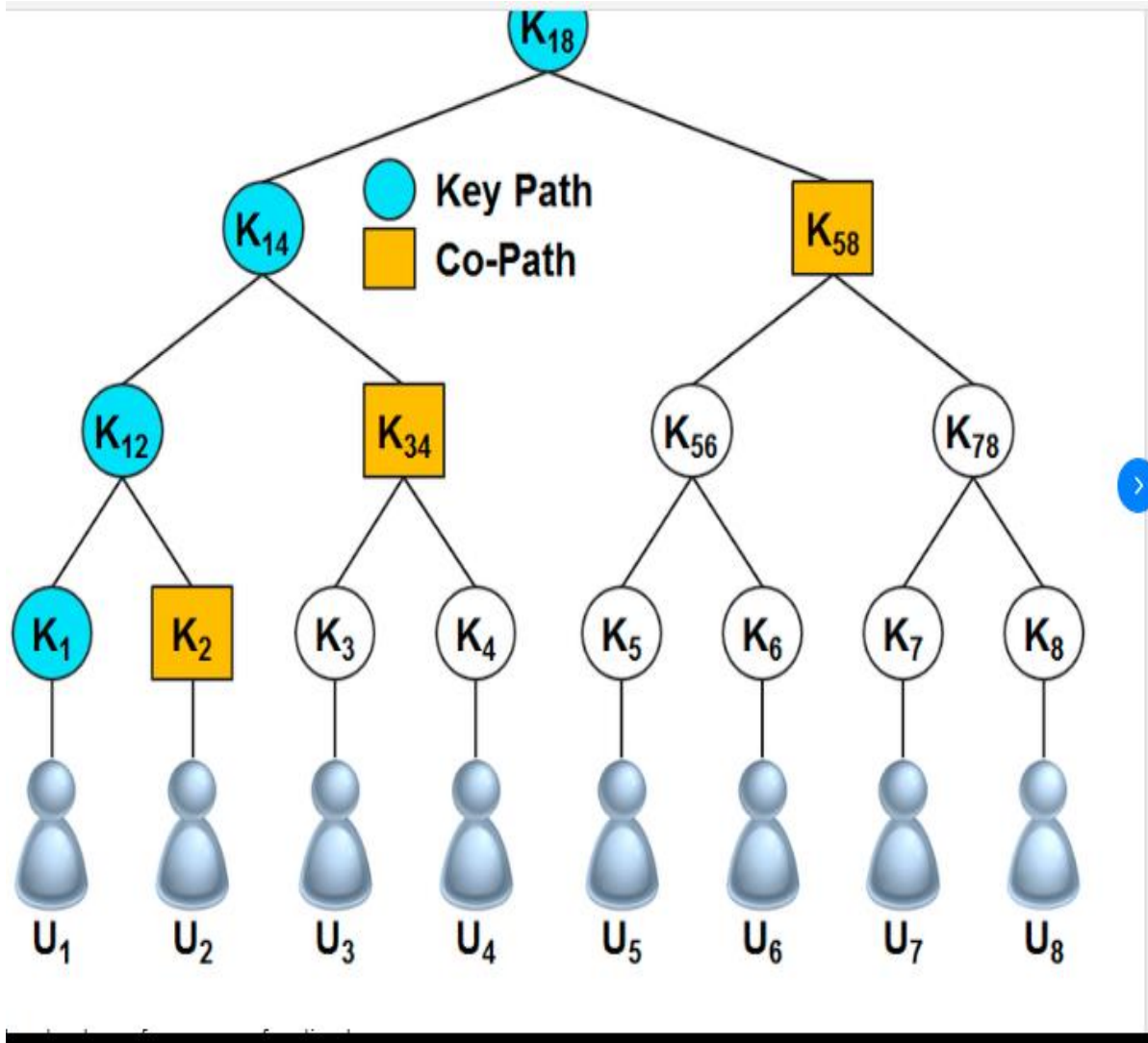

Kang, J., Han, J., & Park, J. H. (2015).

3.3 Rivest Shamir Adleman (RSA)

RSA (Rivest-Shamir-Adleman) is a widely used public-key encryption algorithm. It provides secure data transmission and encryption, essential for online transactions and communications. The algorithm relies on the mathematical principles of prime numbers and modular arithmetic. In RSA, a pair of keys is generated: a public key for encryption and a private key for decryption. The public key can be shared openly, while the private key must remain confidential. RSA is commonly used for secure online transactions, digital signatures, and authentication. Its strength lies in its ability to resist factorization, making it difficult for unauthorized parties to access encrypted data. RSA has become a cornerstone of modern cryptography, ensuring the integrity and confidentiality of digital information. Its impact on secure online interactions has been significant, facilitating trust and security in the digital world.

Illustration of Illustration of RSA Encryption

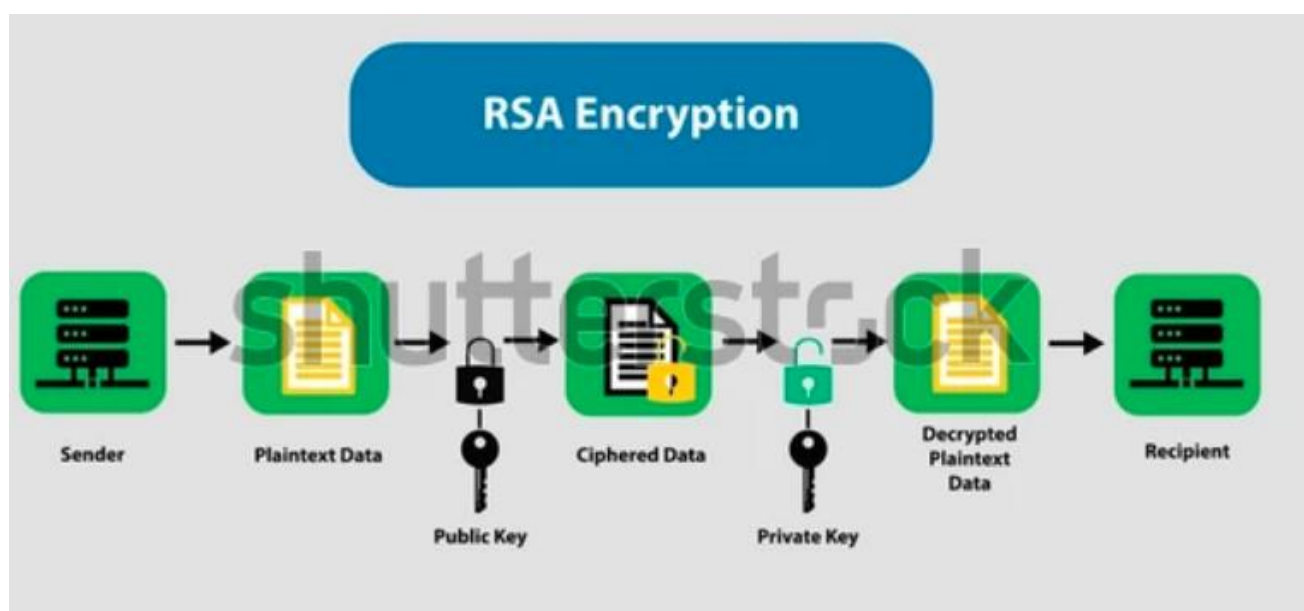

(From <https://www.shutterstock.com/search/rsa-encryption>)

3.4 El Gamal cryptosystem

The ElGamal cryptosystem is a popular application of asymmetric cryptography, which uses a pair of keys: a public key for encryption and a private key for decryption. Developed by Taher ElGamal in 1985, it is based on the difficulty of computing discrete logarithms in a finite field. This

asymmetric approach ensures that the encryption process can be made public without compromising the security of the decryption process. The ElGamal algorithm consists of three main components: key generation, encryption, and decryption. In key generation, a large prime number and a generator are selected, and the public and private keys are computed. During encryption, the plaintext is multiplied by the public key, and in decryption, the ciphertext is multiplied by the private key to recover the original message. ElGamal's use of asymmetric cryptography makes it a reliable choice for secure communication over insecure channels.

Diagrammatic Illustration of El Gamal cryptosystem

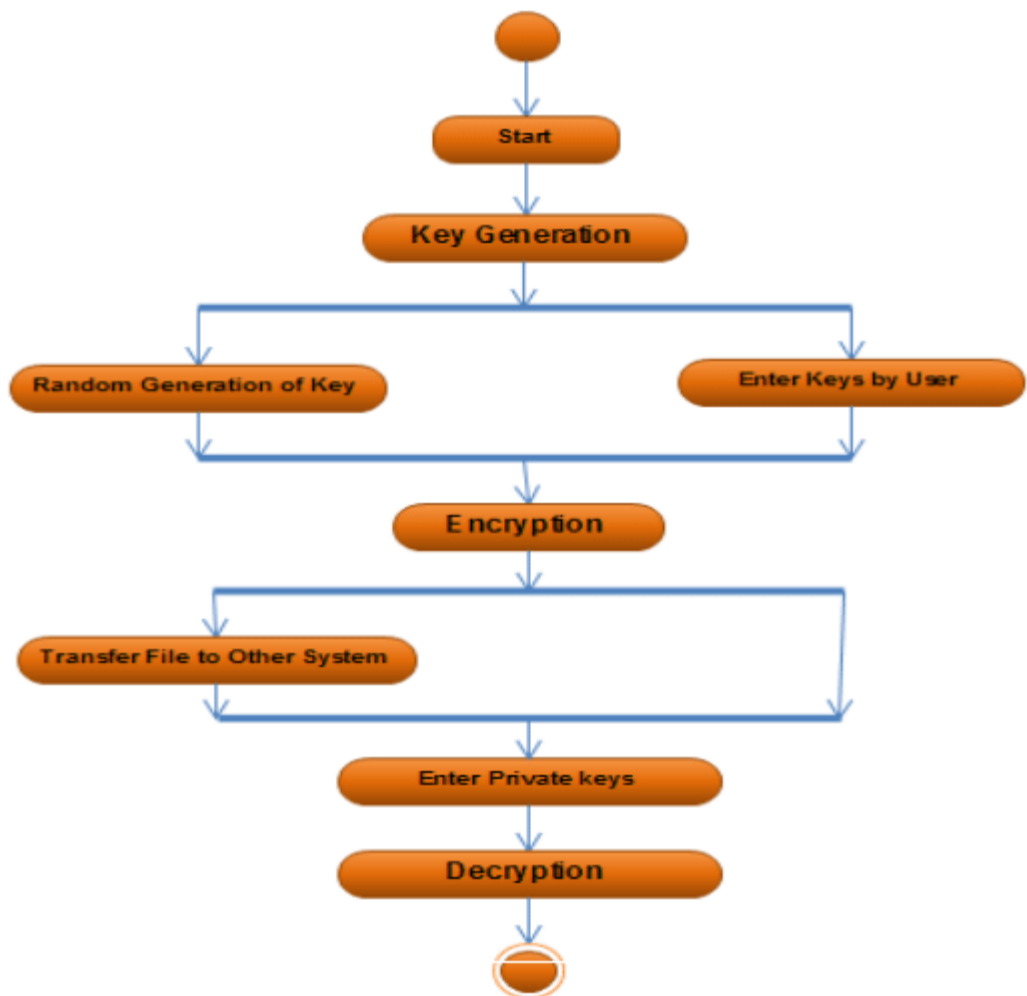

Bhowmick, S. K., Das, S. K., Chakraborty, T., & Vincent, P. D. R. (2016)

4.0 Discussion

Now that you have completed this unit, you should have a deep understanding of the applications of asymmetric cryptography. This unit explored the various techniques that underlie modern cryptographic systems, preparing you to tackle real-world challenges in cybersecurity, data privacy, and digital trust. Asymmetric cryptography plays a vital role in protecting data and maintaining trust in various industries, from e-commerce transactions to digital signatures, secure messaging, and blockchain technology. You learned about the Diffie-Hellman key exchange, which enables secure key establishment between parties over an insecure communication channel.

One-Way Functions (OWFs) are another crucial application of asymmetric cryptography, ensuring the security of various cryptographic protocols. You saw how OWFs are used to enable secure key establishment, digital signatures, and encryption schemes. The unit also covered popular cryptographic algorithms like RSA and ElGamal. RSA provides secure data transmission and encryption, essential for online transactions and communications. ElGamal uses a pair of keys for encryption and decryption, ensuring secure communication over insecure channels.

By mastering these concepts, you will be able to design and implement secure communication systems using asymmetric cryptography. You'll understand how to analyze and compare different asymmetric cryptographic algorithms in terms of their security, performance, and applications. As you progress, consider the real-world implications of asymmetric cryptography. How can you apply these concepts to address emerging challenges in cybersecurity and data privacy? What innovative solutions can you develop using asymmetric cryptography?

Remember, asymmetric cryptography is a continuously evolving field. Stay updated on the latest research and advancements to remain competitive in the industry. Now, let's assess your understanding through the self-assessment exercises.

5.0 Self-Assessment Exercise(s)

1. Compare and contrast the security, performance, and applications of RSA and ElGamal cryptosystems.
2. Describe the key generation, encryption, and decryption processes of Diffie-Hellman key exchange and RSA encryption.
3. Describe how you would use the ElGamal cryptosystem to encrypt and decrypt the message, and explain the benefits of using this approach

Answers

Exercise 1: Comparison of RSA and ElGamal Cryptosystems

RSA and ElGamal are popular public-key encryption algorithms used for secure data transmission.

Similarities:

- Both use asymmetric cryptography.
- Both provide secure key exchange and encryption.
- Both are widely used in digital signatures and secure online transactions.

Differences:

- Security: RSA is considered more secure due to its larger key size and computational complexity.
- Performance: ElGamal is faster than RSA for encryption but slower for decryption.
- Key generation: RSA uses prime numbers, while ElGamal uses discrete logarithms.
- Applications: RSA is commonly used for digital signatures and secure web browsing, while ElGamal is used for secure email and messaging.

Exercise 2: Diffie-Hellman Key Exchange and RSA Encryption Processes

Diffie-Hellman Key Exchange:

- Key generation: Each party generates a public and private key pair.
- Public key exchange: Parties exchange their public keys.
- Shared secret key computation: Each party computes the shared secret key using the other's public key.

RSA Encryption:

- Key generation: Generate public and private key pair using prime numbers.
- Encryption: Encrypt data using the public key.
- Decryption: Decrypt data using the private key.

Exercise 3: ElGamal Cryptosystem Encryption and Decryption

Encryption Process:

- Choose a large prime number (p) and generator (g).
- Generate public key (y) and private key (x).
- Encrypt message (m) using public key: $c = m * y^x \text{ mod } p$.

Decryption Process:

- Decrypt ciphertext (c) using private key: $m = c * x^{(-1)} \text{ mod } p$.

Benefits of ElGamal:

- Secure key exchange without actually exchanging keys.
- Fast encryption and decryption.
- Suitable for large-scale applications.

6.0 Conclusion

The unit has explored various applications of asymmetric cryptography, including the Diffie-Hellman key exchange, One-Way Functions, RSA, and the ElGamal cryptosystem. These techniques enable secure communication over insecure channels, ensuring the confidentiality, integrity, and authenticity of sensitive information.

Asymmetric cryptography has far-reaching implications in various industries, including e-commerce, digital signatures, secure messaging, and blockchain technology. Its significance extends beyond secure communication, enabling trust and security in the digital world. By understanding the principles and applications of asymmetric cryptography, individuals can design and implement secure communication systems, addressing real-world challenges in cybersecurity, data privacy, and digital trust.

7.0 Summary

Applications of Asymmetric Cryptography introduces asymmetric cryptography and its applications, covering the Diffie-Hellman key exchange, One-Way Functions (OWFs), RSA (Rivest-Shamir-Adleman) cryptosystem, and ElGamal cryptosystem. The unit explores how

asymmetric cryptography enables secure key establishment, digital signatures, encryption schemes, and secure communication over insecure channels, emphasizing its importance in various industries and its role in shaping the future of secure digital interactions.

8.0 Tutor Marked Assignment

1. Develop a comprehensive report explaining the concept of asymmetric cryptography, its principles, and its applications in secure communication.
2. Compare and contrast the RSA and ElGamal cryptosystems, highlighting their strengths and weaknesses.
3. Describe how the Diffie-Hellman key exchange enables secure key establishment, and explain its significance in asymmetric cryptography

9.0 Further Readings

Oppliger, R. (2021). *Cryptography 101: From Theory to Practice*. Artech House.
<https://www.esecurity.ch/Slides/Crypto101/c5.pdf>

Silva, B. M., Rodrigues, J. J., Canelo, F., Lopes, I. M., & Lloret, J. (2019). Towards a cooperative security system for mobile-health applications. *Electronic Commerce Research*, 19, 629-654.

https://www.academia.edu/34129937/Towards_a_cooperative_security_system_for_mobile_health_applications

Bhowmick, S. K., Das, S. K., Chakraborty, T., & Vincent, P. D. R. (2016). MODIFIED ELGAMAL CRYPTOSYSTEM FOR PUBLIC-KEY ENCRYPTION AND DIGITAL SIGNATURE.

https://www.researchgate.net/publication/316886783_Modified_elgamal_cryptosystem_for_public-key_encryption_and_digital_signature

UNIT 3: Key Management

Contents

1.0 Introduction

2.0 Intended Learning Outcomes

3.0 Key Management

3.1 Importance of Key Management

3.2 Key Management Protocols and Standards

3.3 Public Key Infrastructure

3.4 Certificates and Certification Authority

4.0 Discussion

Self-Assessment Exercise(s)

5.0 Conclusion

6.0 Summary

7.0 Tutor Marked Assignment

8.0 Further Readings

1.0 Introduction

In this unit, we will explore the critical concepts and techniques used to manage cryptographic keys, a crucial aspect of data security and privacy. Key management is the process of creating, distributing, storing, and revoking keys, ensuring secure communication and data protection. As we rely increasingly on digital technologies, the importance of key management cannot be overstated. It is essential for maintaining confidentiality, integrity, and authenticity in various contexts, from secure online transactions to sensitive data storage. Throughout this unit, we will delve into the principles, methods, and tools used in key management, discussing best practices, challenges, and real-world applications. By the end of this unit, you will have a deep understanding of the critical role key management plays in ensuring the security and privacy of digital information.

2.0 Intended Learning Outcomes

1. Explain the fundamental concepts and principles of key management
2. Analyze the different types of cryptographic keys and their uses
3. Evaluate the security and privacy risks associated with key management.

3.0 Key Management

Key Management is centered around the importance of good key management, standards and protocols, and the intricacies of Public Key Infrastructure (PKI) in cryptography. By exploring these areas, students will gain a deeper understanding of the critical role that key management plays in ensuring the security and privacy of cryptographic systems.

Key Management Taxonomy

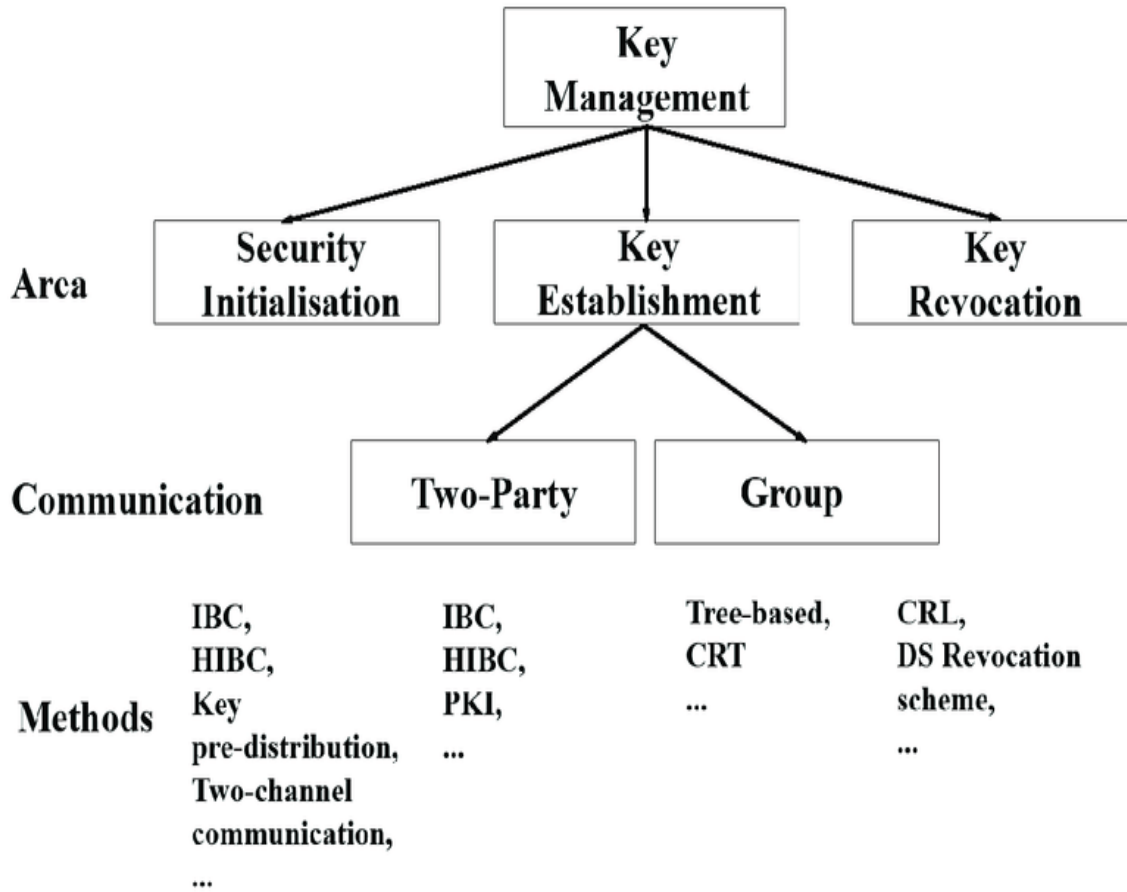

Menesidou, S. A., Katos, V., & Kambourakis, G. (2017).

3.1 Importance of Key Management

Key management is crucial for ensuring the security and privacy of cryptographic systems. Importance of Key Management include the following:

- **Secure Data Protection:** Keys are used to encrypt and decrypt data, making key management essential for protecting sensitive information.
- **Authentication and Verification:** Keys are used to create digital signatures, ensuring the authenticity and integrity of data.
- **Access Control:** Key management enables control over who has access to encrypted data and systems.
- **Privacy:** Proper key management ensures that personal and sensitive information remains confidential.
- **Compliance:** Many regulations require robust key management practices to ensure data security and privacy.
- **Business Continuity:** Key management ensures that critical business operations are not disrupted by key-related issues.
- **Trust and Reputation:** Effective key management helps maintain trust and reputation by preventing data breaches and cyber attacks.

Therefore, key management is essential for maintaining the confidentiality, integrity, and authenticity of data, and is a critical component of various security systems.

3.2 Key Management Protocols and Standards

Key management protocols and standards are essential components of cryptographic systems, ensuring the secure creation, distribution, storage, and revocation of cryptographic keys. These protocols and standards provide a framework for managing keys throughout their lifecycle, maintaining the confidentiality, integrity, and authenticity of data. Some widely used key management protocols include:

- i. **Public Key Infrastructure (PKI):** manages public-private key pairs for encryption and digital signatures.
- ii. **Internet Key Exchange (IKE):** establishes secure key exchange for IPsec VPNs
- iii. **Transport Layer Security (TLS):** manages keys for secure web browsing
- iv. **Secure/Multipurpose Internet Mail Extensions (S/MIME):** secures email communication using public-key encryption

Key management standards include:

- i. X.509: specifies the format for public-key certificates
- ii. PKCS (Public-Key Cryptography Standards): defines standards for various cryptographic operations
- iii. NIST Special Publication 800-57: provides guidelines for key management
- iv. ANSI X9.24: specifies key management requirements for financial institutions

These protocols and standards ensure that keys are generated, distributed, stored, and revoked securely, minimizing the risk of unauthorized access or key compromise. By following established key management protocols and standards, organizations can maintain the security and privacy of their data, ensuring trust and compliance in various industries. The scope of this unit will dwell more on one of the key management protocols and standards specifically Public Key Infrastructure (PKI).

3.3 Public Key Infrastructure

Public Key Infrastructure (PKI) is both a key management protocol and a standard. As a protocol, PKI defines the procedures and processes for creating, managing, and using public-private key pairs, including:

- i. Certificate issuance and revocation
- ii. Key pair generation and distribution
- iii. Digital certificate management

As a standard, PKI defines the formats, algorithms, and policies for implementing the protocol, including:

- i. X.509 certificate format
- ii. RSA and elliptic curve cryptography algorithms
- iii. Certificate policies and practice statements

PKI is a comprehensive framework that combines both protocols and standards to provide a robust and scalable key management solution for secure communication, authentication, and digital

signatures. It is a framework that supports the use of public-key cryptography, facilitating secure communication, authentication, and digital signatures. In a PKI system:

- i. Certificate Authority (CA) issues digital certificates, binding public keys to user identities
- ii. Registration Authority (RA) verifies user identities and requests certificates from the CA
- iii. Key Pair Generator creates public-private key pairs
- iv. A Certificate Revocation List (CRL) or Online Certificate Status Protocol (OCSP) revokes and checks the status of certificates

PKI provides several benefits, including:

- i. Secure key exchange and encryption
- ii. Authentication and verification of identities
- iii. Digital signatures for non-repudiation
- iv. Trust and validation of public keys
- v. Scalability and flexibility for large-scale deployments.

PKI is widely used in various applications, such as:

- i. Secure web browsing (HTTPS)
- ii. Virtual private networks (VPNs)
- iii. Email encryption (S/MIME)
- iv. Code signing and software updates
- v. Digital signatures and document authentication

By implementing PKI, organizations can establish a robust key management system, ensuring the confidentiality, integrity, and authenticity of data, and maintaining trust and compliance in various industries.

3.4 Certificates and Certification Authority

Certificates and Certification Authority (CA) play a crucial role in establishing trust and authenticity in secure communication. A digital certificate is an electronic document that binds a

public key to an individual's or organization's identity. It contains information such as the subject's name, public key, and expiration date, and is signed by a trusted CA. Certificates are used for authentication, encryption, and digital signatures.

A Certification Authority (CA) is a trusted entity that issues and manages digital certificates. The CA verifies the identity of the certificate requester and ensures that the public key is genuine. CAs issue certificates following a strict policy and procedure, ensuring the integrity and trustworthiness of the certificates. There are different types of CAs, including:

- i. Root CAs: the highest level of trust, anchoring the PKI hierarchy
- ii. Intermediate CAs: issue certificates on behalf of the Root CA
- iii. Issuing CAs: issue certificates to end-entities

The CA's digital signature on a certificate ensures its authenticity and integrity, allowing relying parties to trust the certificate and establish secure communication. In essence, CAs act as trusted third-party validators, enabling secure transactions and communication over the internet.

4.0 Discussion

In this unit, we explored the critical concepts and techniques used to manage cryptographic keys, ensuring secure communication and data protection. Key management is essential for maintaining confidentiality, integrity, and authenticity in various contexts, from secure online transactions to sensitive data storage. Effective key management involves creating, distributing, storing, and revoking keys, ensuring secure key exchange and encryption, authenticating and verifying identities, and maintaining trust and compliance.

Public Key Infrastructure (PKI) is a comprehensive framework combining protocols and standards for robust key management. PKI defines procedures and processes for creating, managing, and using public-private key pairs, including certificate issuance and revocation, key pair generation and distribution, and digital certificate management.

Certification Authorities (CAs) play a crucial role in establishing trust and authenticity. CAs issue digital certificates, binding public keys to individual or organizational identities, and ensure the integrity and trustworthiness of certificates.

Key management standards and protocols, such as X.509, PKCS, NIST Special Publication 800-57, and ANSI X9.24, ensure secure key management, minimizing the risk of unauthorized access or key compromise. As you progressed through this unit, the real-world applications and challenges of key management was considered. To reinforce your understanding, reflect on the importance of key management in cryptographic systems, compare and contrast different key management protocols and standards, and describe the role of Certification Authorities in establishing trust and authenticity.

5.0 Self-Assessment Exercise(s)

1. Explain the importance of key management in ensuring the security and privacy of cryptographic systems.
2. Evaluate the security risks associated with poor key management practices, and discuss how PKI and certificate authorities can mitigate these risks.
3. Describe the role of a Certification Authority (CA) in a PKI system

Answers

Exercise 1: Importance of Key Management

Key management is crucial in ensuring the security and privacy of cryptographic systems. Effective key management enables secure key exchange, encryption, and decryption, protecting sensitive information from unauthorized access. Key management ensures:

- Secure key generation, distribution, storage, and revocation
- Authentication and verification of identities
- Confidentiality, integrity, and authenticity of data
- Compliance with regulatory requirements

Poor key management practices can compromise the security of cryptographic systems, allowing unauthorized access, data breaches, and cyber attacks.

Exercise 2: Security Risks and Mitigation

Poor key management practices pose significant security risks, and these include:

- Key compromise or theft

- Unauthorized access to sensitive data
- Data breaches and cyber attacks
- Compliance violations

PKI and Certificate Authorities (CAs) mitigate these risks by:

- Providing secure key exchange and encryption
- Authenticating and verifying identities
- Ensuring trust and compliance
- Managing key revocation and expiration

PKI's robust framework and CAs' trusted third-party validation ensure secure communication, protecting against security threats.

Exercise 3: Role of Certification Authority (CA)

A Certification Authority (CA) plays a vital role in a PKI system, its roles include

- Issues digital certificates binding public keys to identities
- Verifies identity and ensures certificate authenticity
- Manages certificate revocation and expiration
- Maintains trust and compliance

CAs act as trusted third-party validators, ensuring:

- Secure communication and data protection
- Authentication and verification of identities
- Compliance with regulatory requirements

6.0 Conclusion

Key management is a critical component of cryptographic systems, ensuring the security and privacy of data. Effective key management practices, including the use of Public Key

Infrastructure (PKI) and certificates, are essential for maintaining trust and authenticity in secure communication. Adherence to key management protocols and standards is crucial for maintaining the security and privacy of data, and for ensuring trust and compliance in various industries.

7.0 Summary

This unit covers the fundamental concepts and techniques of key management, a crucial aspect of data security and privacy. Key management involves creating, distributing, storing, and revoking keys to ensure secure communication and data protection. It explores the importance of key management, key management protocols and standards, and Public Key Infrastructure (PKI) in cryptography. PKI is a comprehensive framework that defines procedures and processes for creating, managing, and using public-private key pairs. The unit also covers certificates and Certification Authorities (CAs), which play a crucial role in establishing trust and authenticity in secure communication.

8.0 Tutor Marked Assignment

1. Define key management and its importance in cryptography
2. Explain how key management ensures secure communication and data protection.
3. Explain how key management ensures secure communication and data protection

9.0 Further Readings

Harvin, H. (2023). *HANDBOOK OF CRYPTOGRAPHY*. Henry Harvin. https://www.flipkart.com/handbook-of-cryptography/p/itm28d8b016ea0eb?pid=9788196413903&lid=LSTBOK9788196413903UJUTA5&marketplace=FLIPKART&cmpid=content_book_8965229628_gmc

Williams, W. (2021). *Creating an Information Security Program from Scratch*. CRC Press. <https://www.taylorfrancis.com/books/mono/10.1201/9781003093688/creating-information-security-program-scratch-walter-williams>

Menesidou, S. A., Katos, V., & Kambourakis, G. (2017). Cryptographic key management in delay tolerant networks: A survey. *Future Internet*, 9(3), 26. <https://www.mdpi.com/1999-5903/9/3/26>

Module 4: Practical Applications of Cryptography

Introduction

Having been introduced to the principles and techniques of cryptography in the previous modules, Module 4 will now bridge the gap between theory and practice, serving as a comprehensive guide to the practical applications of cryptography in computer technology. By the end of this module, you will have gained a deep understanding of various cryptographic techniques and their real-world applications, preparing you to effectively apply your knowledge in practical scenarios.

Unit 1: Applications and Advanced Topics in Cryptography

Unit 2: Authentication and Identification (Protocols, Challenge-Response)

UNIT 1: Applications and Advanced Topics in Cryptography

Contents

1.0 Introduction

2.0 Intended Learning Outcomes

3.0 Applications and Advanced Topics in Cryptography.

3.1 Applications of Cryptography

3.2 Advanced Topics in Cryptography

4.0 Discussion

5.0 Self-Assessment Exercise(s)

6.0 Conclusion

7.0 Summary

8.0 Tutor Marked Assignment

9.0 Further Readings

1.0 Introduction

As technology advances, so do the techniques and applications of cryptography. In the field of computer science and information security, cryptography has become an essential tool for protecting data, privacy, and security. The applications of cryptography are vast and diverse, ranging from secure online transactions and communication networks to digital signatures and cryptocurrencies.

As we delve into the advanced topics in cryptography, we will explore the latest developments, techniques, and protocols that are shaping the future of secure communication. From

homomorphic encryption and multi-party computation to post-quantum cryptography and blockchain security, we will examine the cutting-edge technologies that are redefining the boundaries of cryptography.

2.0 Intended Learning Outcomes

1. Students will be able to analyze and evaluate the use of cryptographic techniques in various real-world applications, such as secure online transactions, digital signatures, and cryptocurrencies.
2. Students will be able to critically evaluate emerging trends and technologies in cryptography.
3. Students will be able to apply cryptographic solutions to real-world problems, demonstrating an understanding of the trade-offs between security, performance, and usability.

3.0 Applications of Cryptography and Advanced topics in Cryptography

Cryptography, the practice and study of secure communication in the presence of adversaries, has numerous applications in today's digital world. Its primary goal is to protect the confidentiality, integrity, and authenticity of information, ensuring secure data transmission and storage.

In view of the aforementioned, there have been emergence of advanced topics which represent the cutting-edge of cryptography research, addressing emerging challenges and opportunities in secure communication, data protection, and privacy preservation. As technology advances and threats evolve, understanding and developing advanced cryptographic techniques is crucial for ensuring the long-term security and integrity of our digital landscape.

3.1 Applications of Cryptography

Although this course has introduced us to the roles, significance, and applications of cryptography in digital communications, we aim to further emphasize its importance and explore its applications in securing online communications across various fields. By doing so, we can deepen our understanding of cryptography's crucial role in protecting sensitive information and ensuring the integrity of digital interactions. Cryptography has numerous applications in various fields, including:

1. **Secure Online Transactions:** Cryptography enables secure online transactions, such as online banking and e-commerce, by protecting sensitive information like passwords and credit card numbers.
2. **Data Protection:** Cryptography helps protect personal data and sensitive information from unauthorized access, ensuring privacy and security.
3. **Secure Communication:** Cryptography enables secure communication over the internet, such as encrypted emails and chats, keeping conversations confidential.
4. **Digital Signatures:** Cryptography facilitates digital signatures, which authenticate the sender's identity and ensure the integrity of digital messages.
5. **Cybersecurity:** Cryptography plays a crucial role in cybersecurity, protecting against cyber threats and attacks by encrypting sensitive information.
6. **Blockchain and Cryptocurrencies:** Cryptography is the foundation of blockchain technology and cryptocurrencies like Bitcoin, ensuring secure and decentralized transactions.
7. **Military and Defense:** Cryptography has long been used in military and defense applications to secure communication and protect sensitive information.
8. **Cloud Security:** Cryptography ensures the security and privacy of data stored in cloud storage services.
9. **Internet of Things (IoT):** Cryptography secures communication between IoT devices, preventing unauthorized access and ensuring the integrity of data.
10. **Artificial Intelligence and Machine Learning:** Cryptography has applications in secure AI and ML model training and deployment, protecting sensitive data and intellectual property.

3.1 Advanced Topics in Cryptography

The field of cryptography is in a state of continuous evolution, driven by the escalating threats and attacks on online communication. As technology advances, so do the methods employed by malicious actors to compromise sensitive information. In response, cryptography is expanding its scope to address these emerging challenges. Therefore, this unit will serve as a window giving

students a glimpse of some advancement in cryptography. Some advanced topics in cryptography include:

- **Homomorphic Encryption:** This technique enables computations on encrypted data without decrypting it first, ensuring data privacy and security in cloud computing, big data analytics, and artificial intelligence applications.
- **Zero-Knowledge Proofs:** This method allows one party to prove a statement is true without revealing any information beyond the validity of the statement, useful for authentication, identity verification, and secure voting systems.
- **Multi-Party Computation:** This approach enables multiple parties to jointly perform computations on private data without revealing their individual inputs, applicable in secure data sharing, collaborative machine learning, and privacy-preserving data analysis.
- **Quantum Cryptography:** This area explores the intersection of quantum mechanics and cryptography, including quantum key distribution and post-quantum cryptography, to future-proof against quantum computer attacks and ensure long-term security.
- **Code-Based Cryptography:** This field investigates the use of error-correcting codes for cryptographic purposes, such as the McEliece cryptosystem, offering an alternative to number theory-based cryptography and potentially providing more efficient and secure solutions.
- **Lattice-Based Cryptography:** This area examines the application of lattice problems, like the shortest vector problem, to construct cryptographic primitives, including public-key encryption and digital signatures, which are thought to be resistant to quantum attacks.
- **Secure Multi-Party Computation:** This topic focuses on enabling multiple parties to jointly perform computations on private data without revealing their individual inputs, ensuring privacy and security in collaborative environments.
- **Functional Encryption:** This approach allows users to compute functions over encrypted data without decrypting it first, enabling more flexible and secure data sharing and analysis.

These advanced topics in cryptography are crucial for addressing the evolving challenges of online security, including:

- i. Mitigating the risks associated with cloud computing and big data analytics
- ii. Protecting against quantum computer attacks
- iii. Ensuring privacy and security in collaborative environments
- iv. Developing more efficient and secure cryptographic primitives
- v. Addressing the challenges of secure data sharing and analysis

By exploring and advancing these areas, researchers and practitioners can develop innovative solutions to stay ahead of emerging threats and ensure the long-term security and privacy of online communication.

4.0 Discussion

As technology advances, cryptography plays an increasingly vital role in protecting data, privacy, and security. This unit explores the diverse applications of cryptography, from secure online transactions and communication networks to digital signatures and cryptocurrencies. You will analyze and evaluate cryptographic techniques in real-world applications, critically assess emerging trends and technologies, and apply cryptographic solutions to practical problems. Understanding the trade-offs between security, performance, and usability is crucial.

Cryptography's primary goal is to protect confidentiality, integrity, and authenticity. Its applications include secure online transactions, data protection, secure communication, digital signatures, cybersecurity, blockchain, and cryptocurrencies. Advancements in cryptography address emerging challenges. Topics include homomorphic encryption, zero-knowledge proofs, multi-party computation, quantum cryptography, code-based cryptography, lattice-based cryptography, secure multi-party computation, and functional encryption. These advanced topics are essential for:

- Mitigating cloud computing and big data analytics risks
- Protecting against quantum computer attacks
- Ensuring privacy and security in collaborative environments
- Developing efficient and secure cryptographic primitives
- Addressing secure data sharing and analysis challenges

By exploring these areas, you will develop expertise in cryptography's latest developments, techniques, and protocols. You'll understand how cryptography shapes the future of secure communication. Throughout this unit, engage with course materials, discuss emerging trends and technologies, and reflect on cryptography's role in protecting sensitive information..

5.0 Self-Assessment Exercise(s)

1. Explain the significance of cryptography in secure online transactions.
2. Evaluate the impact of emerging trends and technologies on cryptography.
3. Discuss the role of advanced cryptographic techniques in addressing emerging challenges

Answers

Exercise 1: Significance of Cryptography in Secure Online Transactions

Cryptography plays a vital role in secure online transactions, ensuring confidentiality, integrity, and authenticity. Its significance includes:

- Protecting sensitive information (passwords, credit card numbers)
- Preventing unauthorized access and data breaches
- Ensuring secure data transmission and storage.
- Facilitating trust and confidence in online transactions
- Compliance with regulatory requirements

Cryptography enables secure online transactions through:

- Encryption (SSL/TLS, AES)
- Digital signatures (RSA, ECDSA)
- Secure key exchange (Diffie-Hellman, Elliptic Curve)
- Authentication protocols (Kerberos, OAuth)

Exercise 2: Impact of Emerging Trends and Technologies on Cryptography

Emerging trends and technologies significantly impact cryptography, through:

- Quantum Computing: Potential to break current encryption algorithms
- Artificial Intelligence/Machine Learning: Enhanced cryptographic attacks and defenses

- Internet of Things (IoT): Increased attack surfaces and data vulnerability
- Cloud Computing: Data protection and key management challenges
- Blockchain and Cryptocurrencies: New cryptographic applications and innovations

To address these challenges, cryptography adapts through:

- Post-quantum cryptography (lattice-based, code-based)
- Homomorphic encryption and secure multi-party computation
- Advanced digital signature schemes (quantum-resistant)
- Enhanced key management and authentication protocols

Exercise 3: Role of Advanced Cryptographic Techniques

Advanced cryptographic techniques address emerging challenges, through the following:

- Homomorphic Encryption: Secure cloud computing and data analysis
- Zero-Knowledge Proofs: Enhanced privacy and authentication
- Multi-Party Computation: Secure collaborative environments
- Quantum Cryptography: Future-proof against quantum attacks
- Functional Encryption: Flexible and secure data sharing

These techniques enable:

- Secure data sharing and analysis
- Privacy-preserving authentication
- Resilience against quantum attacks
- Efficient and secure cryptographic primitives
- Compliance with evolving regulatory requirements

6.0 Conclusion

Cryptography plays a vital role in securing online communications and protecting sensitive information across various fields. Its applications are diverse, ranging from secure online transactions and digital signatures to cloud security and blockchain technology. As technology advances and threats evolve, the importance of cryptography cannot be overstated. The exploration of advanced topics in cryptography, such as homomorphic encryption, zero-knowledge proofs, and

quantum cryptography, is crucial for addressing emerging challenges and ensuring the long-term security and integrity of our digital landscape. By understanding and developing these cryptographic techniques, we can stay ahead of potential threats and protect sensitive information in an increasingly interconnected world. Ultimately, cryptography is essential for maintaining trust and confidentiality in digital communications, and its continued evolution is critical for securing our digital future.

7.0 Summary

This unit delved into the multifaceted applications of cryptography in securing online communications and protecting sensitive information. It explored various real-world applications, including secure online transactions, digital signatures, cloud security, and blockchain technology. Additionally, the unit introduced advanced topics in cryptography, such as homomorphic encryption, zero-knowledge proofs, and quantum cryptography, highlighting their significance in addressing emerging challenges and threats. By examining the latest developments and techniques in cryptography, this unit provided a comprehensive understanding of the crucial role cryptography plays in maintaining trust and confidentiality in our increasingly interconnected digital world.

8.0 Tutor Marked Assignment

1. Select one advanced topic in cryptography (e.g., homomorphic encryption, zero-knowledge proofs).:
 - Define the concept and explain its significance
 - Describe the cryptographic techniques and protocols involved
 - Discuss potential applications and benefits.
2. Reflect on the emerging trends and technologies in cryptography discussed in the unit. How do these advancements impact the future of secure communication and data protection?

9.0 Further Readings

Handschuh, H., & Lysyanskaya, A. (Eds.). (2023). *Advances in Cryptology—CRYPTO 2023: 43rd Annual International Cryptology Conference, CRYPTO 2023, Santa Barbara, CA, USA, August 20–24, 2023, Proceedings, Part I* (Vol. 14081). Springer Nature. <https://www.springerprofessional.de/en/advances-in-cryptology-crypto-2023/25901324>

Tibouchi, M., & Wang, X. (Eds.). (2023). *Applied Cryptography and Network Security: 21st International Conference, ACNS 2023, Kyoto, Japan, June 19–22, 2023, Proceedings, Part II* (Vol. 13906). Springer Nature. <https://dokumen.pub/applied-cryptography-and-network-security-21st-international-conference-acns-2023-kyoto-japan-june-1922-2023-proceedings-part-i-9783031334870-9783031334887.html>

Klima, R. E., Klima, R., Sigmon, N. P., & Sigmon, N. (2018). *Cryptology: classical and modern*. Chapman and Hall/CRC. <https://www.taylorfrancis.com/books/mono/10.1201/9781315170664/cryptology-richard-klima-richard-klima-neil-sigmon-neil-sigmon>

UNIT 2: Authentication and Identification

Contents

- 1.0 Introduction
- 2.0 Intended Learning Outcomes
- 3.0 Advanced Cryptographic Techniques
 - 3.1 Authentication and Identification
 - 3.2 Protocols and Challenge-Response
- 4.0 Discussion
- 5.0 Self-Assessment Exercise(s)
- 6.0 Conclusion
- 7.0 Summary
- 8.0 Tutor Marked Assignment
- 9.0 Further Readings

1.0 Introduction

In this advanced cryptography course, we will be introduced to the vital components of Authentication and Identification, which are essential for securing online transactions and communications. Authentication verifies the identity of individuals, devices, or entities, ensuring only authorized access. This process involves confirming claimed identities through credentials like passwords, biometrics, or cryptographic keys.

The initial step is Identification, where an identity is claimed and then verified through authentication. Standardized protocols like Kerberos, SSL/TLS, and OAuth facilitate secure authentication, while Challenge-Response mechanisms like CAPTCHA and one-time passwords add an extra layer of security to prevent automated programs or bots from gaining access

2.0 Intended Learning Outcomes

- Students will be able to explain the fundamental concepts of Authentication and Identification.
- Students will be able to analyze and evaluate the effectiveness of Challenge-Response mechanisms like CAPTCHA and one-time passwords in preventing unauthorized access.
- Understand how to verify identities online.

3.0 Advanced Cryptographic Techniques

3.1 Authentication and Identification

Authentication and Identification are crucial components of cryptography, ensuring secure online interactions. Authentication verifies the identity of individuals, devices, or entities, granting access only to authorized users. Identification is the initial step, where an identity is claimed and then verified through authentication. Effective Authentication and Identification are essential for trust and security in online transactions, protecting sensitive information and maintaining the integrity of digital communications.

i. Authentication

Authentication is the process of verifying the identity of individuals, devices, or entities, ensuring that only authorized users gain access to sensitive information or systems. It is a critical component of cryptography, essential for secure online interactions. Authentication confirms that a user or device is who they claim to be, preventing unauthorized access and maintaining the integrity of

digital communications. There are various authentication methods, including passwords, biometric data, and cryptographic keys. Each method has its strengths and weaknesses, and often, multiple methods are used in combination to provide robust security. Authentication is an ongoing process, with users or devices being re-authenticated periodically to ensure continued authorization.

Effective authentication is essential for trust and security in online transactions, communications, and data storage. It protects against identity theft, cyber attacks, and data breaches, ensuring that sensitive information remains confidential and secure. As technology advances, new authentication methods and technologies are being developed to stay ahead of emerging threats and vulnerabilities. By implementing strong authentication measures, individuals and organizations can safeguard their digital assets and maintain the trust of their users and customers.

ii. Identification

In cryptography, identification refers to the process of verifying the identity of a user, device, or system, ensuring that only authorized entities have access to secure information or systems. It involves using cryptographic techniques, such as:

- Digital signatures: verifying the authenticity of a message or document
- Authentication protocols: secure exchange of credentials or tokens
- Public-key infrastructure (PKI): using public-private key pairs for verification
- Zero-knowledge proofs: verifying identity without revealing sensitive information

Advantages of cryptography-based identification include:

- Confidentiality: protecting sensitive information from unauthorized access
- Integrity: ensuring data authenticity and preventing tampering
- Non-repudiation: preventing denial of identity or actions
- Authentication: verifying the identity of users or systems

Secure identification is crucial in various cryptographic applications, including:

- Secure communication protocols (e.g., SSL/TLS)
- Digital currencies and blockchain
- Access control and authentication systems

- Secure online transactions and e-commerce

By leveraging cryptographic techniques, identification in cryptography ensures the secure verification of identities, protecting sensitive information and preventing unauthorized access.

3.2 Protocols and Challenge-Response

Protocols and Challenge-Response are the format, syntax, and semantics of data exchange, ensuring that information is transmitted reliably and securely. They can be used for various purposes, including data transfer, authentication, and network communication.

i. Protocols

In cryptography, protocols are precise, step-by-step procedures that govern the secure exchange of information between parties. These protocols utilize cryptographic techniques, such as encryption, decryption, digital signatures, and authentication, to ensure the:

- Confidentiality: Protection of data from unauthorized access, using encryption algorithms like AES or RSA.
- Integrity: Assurance of data authenticity and prevention of tampering, using digital signatures or message authentication codes (MACs).
- Authentication: Verification of the identity of parties involved, using authentication protocols like Kerberos or SSL/TLS.
- Non-repudiation: Prevention of denial of actions or messages, using digital signatures or other techniques.

Examples of cryptographic protocols include:

- Key exchange protocols (e.g., Diffie-Hellman, RSA) for secure key establishment
- Authentication protocols (e.g., Kerberos, SSL/TLS) for secure authentication
- Secure communication protocols (e.g., IPsec, PGP) for secure data transmission
- Digital signature protocols (e.g., ECDSA, RSA) for secure data signing

By following established cryptographic protocols, individuals and organizations can ensure the secure exchange of sensitive information and protect against various types of attacks.

ii. Challenge-Response

Challenge-Response is a fundamental concept in cryptography, used to authenticate users, devices, or systems. It's a two-step process:

- **Challenge:** One party sends a random or unique value, called a challenge, to the other party.
- **Response:** The receiving party responds with a calculated value, based on the challenge and their secret key or password.

The response is then verified by the challenging party, ensuring the responder has access to the correct secret key or password. This process provides authentication without revealing sensitive information.

Types of Challenge-Response:

- **Password-based:** Using a password or passphrase to generate the response.
- **Token-based:** Utilizing a physical or software token to generate the response.
- **Cryptographic:** Employing cryptographic algorithms, like digital signatures or MACs, to generate the response.

Advantages of Challenge-Response in cryptography include:

- **Mutual Authentication:** Both parties can authenticate each other.
- **Resistance to Replay Attacks:** Challenges are unique, preventing attackers from reusing previous responses.
- **Security:** Challenge-Response provides an additional layer of security, making it harder for attackers to gain unauthorized access.

Some of the applications of Challenge-Response in computer technology and other related fields include:

- **Login Systems:** Secure authentication for users.
- **Network Access:** Secure authentication for devices or systems.
- **Digital Signatures:** Verifying the authenticity of messages or documents.

Challenge-Response is a robust authentication mechanism, widely used in cryptography to ensure secure authentication and prevent unauthorized access.

4.0 Discussion

In this unit, we explore the vital components of cryptography that secure online transactions and communications. Authentication and identification are crucial for verifying identities and granting access only to authorized users. Authentication confirms a user's or device's identity, preventing unauthorized access and maintaining digital communication integrity. Various authentication methods include passwords, biometric data, and cryptographic keys. Effective authentication is essential for trust and security in online transactions, protecting sensitive information and preventing identity theft and cyber attacks.

Identification, on the other hand, verifies a user's, device's, or system's identity using cryptographic techniques like digital signatures, authentication protocols, public-key infrastructure, and zero-knowledge proofs. Secure identification ensures confidentiality, integrity, non-repudiation, and authentication in various applications.

Protocols and challenge-response mechanisms facilitate secure authentication. Protocols govern the secure exchange of information, ensuring confidentiality, integrity, authentication, and non-repudiation. Examples include key exchange protocols, authentication protocols, secure communication protocols, and digital signature protocols.

Challenge-response authentication verifies identities without revealing sensitive information. Types include password-based, token-based, and cryptographic challenge-response. This process provides mutual authentication, resistance to replay attacks, and additional security. By mastering authentication and identification concepts, protocols, and challenge-response mechanisms, you'll develop expertise in securing online transactions and communications.

Engage with course materials, discuss emerging trends, and reflect on cryptography's role in securing online interactions. Your understanding of authentication and identification will enhance your ability to design and implement secure cryptographic systems.

5.0 Self-Assessment Exercise(s)

- Explain the significance of authentication in cryptography.

- Analyze the effectiveness of challenge-response mechanisms in preventing unauthorized access.
- Discuss the role of identification in cryptography and its applications.

Answers

Exercise 1: Significance of Authentication in Cryptography

Authentication is vital in cryptography, ensuring the identity of individuals, devices, or entities.

Its significance includes:

- Verifying claimed identities, preventing impersonation and unauthorized access
- Protecting sensitive information and maintaining data confidentiality
- Preventing identity theft, cyber-attacks, and data breaches
- Ensuring trust and security in online transactions and communications
- Compliance with regulatory requirements

Effective authentication mechanisms, such as passwords, biometric data, and cryptographic keys, safeguard digital interactions.

Exercise 2: Effectiveness of Challenge-Response Mechanisms

Challenge-response mechanisms are highly effective in preventing unauthorized access, through the following mechanisms:

- Mutual authentication: verifies both parties' identities
- Resistant to replay attacks: unique challenges prevent response reuse
- Secure authentication: protects against password guessing and phishing
- Flexibility: supports various authentication methods (passwords, tokens, cryptography)

Examples of effective challenge-response mechanisms include:

- CAPTCHA (Turing tests)
- One-time passwords (OTPs)
- Digital signatures
- Kerberos authentication protocol

Exercise 3: Role of Identification in Cryptography and Applications

Identification plays a crucial role in cryptography, verifying identities through cryptographic techniques such as:

- Digital signatures
- Authentication protocols
- Public-key infrastructure (PKI)
- Zero-knowledge proofs

Applications of identification in cryptography include:

- Secure communication protocols (SSL/TLS)
- Digital currencies and blockchain
- Access control and authentication systems
- Secure online transactions and e-commerce
- Cloud storage and data protection

6.0 Conclusion

Effective Authentication and Identification are crucial components of cryptography, essential for securing online transactions and communications. By utilizing standardized protocols, Challenge-Response mechanisms, and cryptographic techniques, individuals and organizations can ensure the secure verification of identities, protect sensitive information, and prevent unauthorized access. As technology advances, it is essential to stay ahead of emerging threats and vulnerabilities by implementing robust authentication measures and continually evaluating and improving cryptographic protocols and techniques.

6.0 Summary

This unit covers the fundamental concepts of Authentication and Identification in cryptography. Authentication verifies the identity of individuals, devices, or entities, ensuring authorized access, while Identification is the initial step of claiming an identity. The unit explores various authentication methods, including passwords, biometrics, and cryptographic keys, and discusses the importance of standardized protocols like Kerberos, SSL/TLS, and OAuth. Challenge-

Response mechanisms, such as CAPTCHA and one-time passwords, add an extra layer of security. The unit also delves into cryptographic techniques like digital signatures, public-key infrastructure, and zero-knowledge proofs. Effective Authentication and Identification are crucial for trust and security in online transactions, protecting sensitive information and maintaining the integrity of digital communications. By understanding these concepts, individuals and organizations can implement robust security measures to safeguard their digital assets.

8.0 Tutor Marked Assignment

1. Compare and contrast Password-based and Token-based authentication methods. Which one is more secure and why?
2. Explain the concept of Mutual Authentication. How is it achieved using Challenge-Response mechanisms? Provide an example
3. What is the primary purpose of Authentication in cryptography?

9.0 Further Readings

Rawal, B. S., Manogaran, G., & Peter, A. (2023). *Cybersecurity and Identity Access Management*. Singapore: Springer. <https://www.springerprofessional.de/en/cybersecurity-and-identity-access-management/23217208>

Dagur, A., Singh, K., Mehra, P. S., & Shukla, D. K. (Eds.). (2023). *Artificial Intelligence, Blockchain, Computing and Security Volume 1: Proceedings of the International Conference on Artificial Intelligence, Blockchain, Computing and Security (ICABCS 2023), Gr. Noida, UP, India, 24-25 February 2023*. CRC Press. <https://www.routledge.com/Artificial-Intelligence-Blockchain-Computing-and-Security-Volume-1-Proceedings-of-the-International-Conference>

Worrying, M., Mishra, D. K., Joshi, A., & Maheshwari, S. (2023). *Emerging trends in expert applications and security*. V. S. Rathore (Ed.). Springer. https://www.researchgate.net/publication/373359641_Emerging_Trends_in_Expert_Applications_and_Security_-_Proceedings_of_2nd_ICETEAS_2023_Volume_1